



Draft Report

**Mendocino County
Zero Emission Vehicle (ZEV)
and Alternative Fuels Readiness Plan
Update**

Prepared for the
Mendocino Council of Governments

May 21, 2019



This page intentionally left blank

Table of Contents

Introduction and Setting	1
Background/Context.....	2
Goal.....	8
Travel Patterns and Electric Vehicle Ownership	9
Recommended PEV Charging Station Network	22
Implementation Strategy	34
Study Participants and References.....	40
Maps	
1. Travel Contours for Existing and Planned DC Fast Chargers	26
2. Travel Contours for All Level 2 Chargers.....	27
3. Travel Contours for Full Access Chargers	28
4. Travel Contours for Existing and Proposed Open Level 2 Chargers	32
Tables	
1. Population by City in Mendocino County as of 2017	9
2. Employment by City in Mendocino County as of 2015	9
3. Vehicle Ownership in Mendocino County versus Statewide as of January 2018.....	10
4. Electric Vehicle Ownership by City in Mendocino County as of January 2018.....	10
5. Level 2 Open Access Chargers.....	24
6. Level 2 Proprietary Public Chargers.....	25
7. Mendocino County Vehicle Registrations, Population, and Employment	30
8. Existing and Proposed Chargers by Location.....	31
9. Core Network of Level 2 Open Access Chargers	33
10. Selected Large Employers in Mendocino County (100+ Employees)	37
Appendices	
A. Electric Vehicle Charging Station Accessibility Requirements	
B. California Building Officials AB 1236 Toolkit	
C. Sample Regulations to Support Electric Vehicle Infrastructure Development	





This page intentionally left blank

Introduction and Setting

Introduction and Purpose

In its efforts to combat climate change, California has established an ambitious target of reducing greenhouse gas (GHG) emissions by 80 percent relative to 1990 levels by 2050. With approximately 41 percent of California's GHG emissions coming from the transportation sector¹, the State has adopted a multi-pronged strategy to reduce vehicle emissions, including expanded use of electric vehicles as well as vehicles powered by a range of alternative fuels. This includes an ambitious goal of five million electric vehicles on the road by 2030. Based on local characteristics and needs, each region will need to develop its own unique strategy to help achieve this statewide goal. This *Zero Emission Vehicle (ZEV) and Alternative Fuels Readiness Plan* represents the efforts of local stakeholders to help approach this challenge on a countywide level. While this plan considers the development of ZEVs overall, it is primarily focused on the development of plug-in electric vehicles (PEVs), which include both battery electric vehicles (BEVs) and plug-in hybrid electric vehicles (PHEVs). Other ZEVs include hydrogen fuel cell vehicles, which will be discussed in terms of the larger context of developing alternative fuel vehicle infrastructure.

In 2013, the Mendocino Council of Governments (MCOG) and the Mendocino County Air Quality Management District completed the *Mendocino County Zero Emission Vehicle (ZEV) Regional Readiness Plan*, which developed a strategy for implementing a countywide network of publicly accessible electric vehicle charging stations. In 2015, MCOG followed this effort with the *Mendocino County Zero Emission Vehicle (ZEV) Regional Readiness Plan Phase 2 – Feasibility Report*, which provided site-specific evaluations and public outreach to advance implementation of the Plan.

In the four years since the completion of the feasibility study, there have been significant growth and changes in the adoption of PEVs and implementation of charging infrastructure in Mendocino County. As a result, MCOG undertook this update of the 2013 Plan to account for the evolving landscape of PEV adoption and development, to reassess previously identified countywide priorities, and to chart a direction forward. This update includes an assessment of the evolving PEV charging station needs within the County and development of a framework to guide the implementation of PEV-related infrastructure in the coming years in Mendocino County. It also places this in the context of regional planning efforts for the development of other alternative fuels.

¹ CARB, <https://www.arb.ca.gov/cc/inventory/data/data.htm>

Background/Context

The rate of adoption of plug-in electric vehicles (PEV) has increased dramatically in recent years. In 2013, there were 97,507 electric vehicles sold in the U.S. By 2018 that had increased by over 370 percent to 361,307, with future growth projections at 3.5 million by 2025. Nearly half of all electric vehicle sales in the U.S. were in California, where they made up 10 percent of all new vehicle sales in 2018. This growth is likely to continue, especially in California, where incentives for electric vehicle purchases are offered to support the state’s greenhouse gas emission reduction efforts. California has established goals of 5 million electric vehicles on the road by 2030, with 250,000 charging stations in place by 2025.

Several factors have supported the rapid growth in the adoption of electric vehicles:

1. **Increase in battery storage capacity:** The battery range of the top-selling PEVs has increased by an average of over 17 percent *per year* since 2011 (see Plate 1). This has resulted in a dramatic increase in the number of miles that can be driven on a single charge, reducing “range anxiety.”
2. **Increased number of charging stations:** The number of charging stations has increased significantly as well. At the time the 2013 Plan was completed only five public electric vehicle charging stations had been installed in Mendocino County – two in Ukiah, and one each in Fort Bragg, Willits, and Hopland. At the time this Update was undertaken, there were more than 40 public charging stations. In addition, funding has been awarded for 11 DC fast chargers – which enable users to charge their batteries to approximately 80 percent in 30 minutes – along the US 101 corridor. The faster charging time, in combination with the reduction in the frequency of charging, will make PEVs a more attractive option for longer trips.
3. **Reduced price of vehicles:** As the battery storage capacity has increased, the cost per kWh has dropped significantly – 50 percent between 2010 and 2018 – making electric vehicles more cost-competitive with gasoline powered vehicles. This trend is projected to continue in the coming years (see Plate 2). Given the availability of federal and state tax credits, as well as other incentives, PEVs are more affordable than ever before.

As these trends continue, PEVs are anticipated to continue to grow as a share of the market and planning for the implementation of charging infrastructure will be of growing importance.

Plate 1: Battery Range Increases for Selected Electric Vehicles

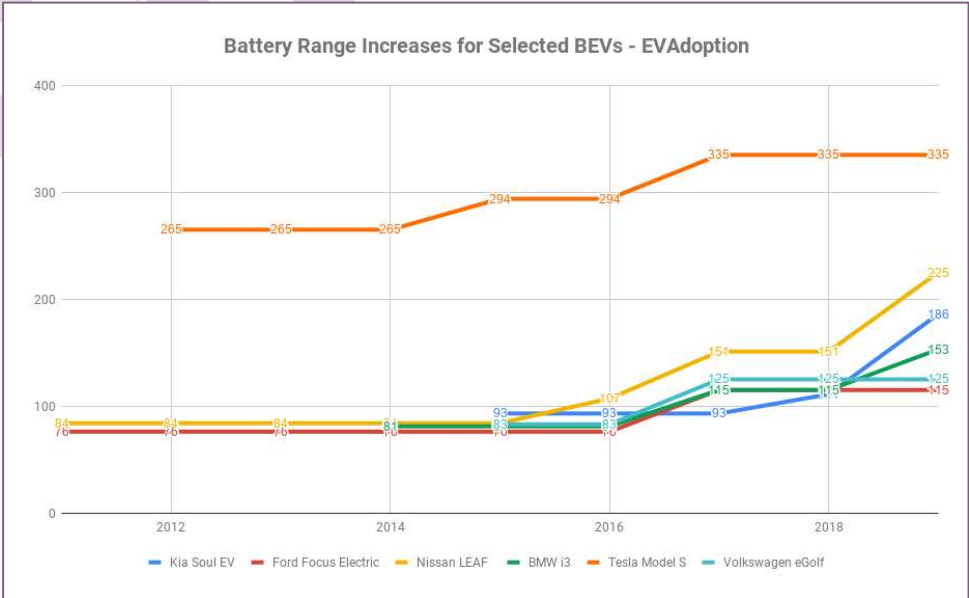

BEVs (Available in the US) Battery Range Increases												
BEV Model	2011	2012	2013	2014	2015	2016	2017	2018	2019	Increase in Miles	% Increase	Average Annual Increase Thru 2019
Kia Soul EV	-	-	-	-	93	93	93	111	186	93	100%	33.3%
Ford Focus Electric	76	76	76	76	76	76	115	115	115	39	51%	8.6%
Nissan LEAF	84	84	84	84	84	107	151	151	225	141	168%	21%
BMW i3	-	-	-	81	81	81	115	115	153	72	89%	17.8%
Tesla Model S	-	265	265	265	294	294	335	335	335	70	26%	5.3%
Volkswagen eGolf	-	-	-	-	83	83	125	125	125	42	51%	25.3%
Average	80	142	142	127	119	122	156	159	190	110	137%	17.2%

Source: <https://evadoption.com/us-bev-battery-range-increases-an-average-17-per-year-and-38-miles-each-model-update/>

Plate 2: Recent and Projected Cost of Electric Vehicle Batteries

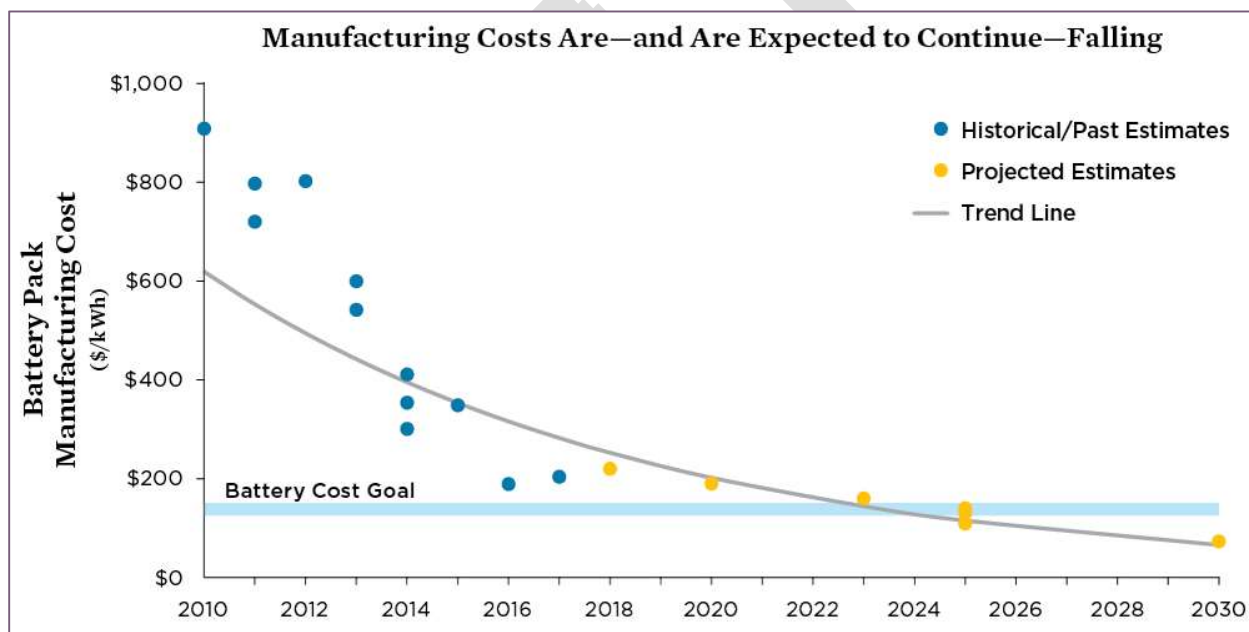

Source: <https://www.ucsusa.org/clean-vehicles/electric-vehicles/electric-cars-battery-life-materials-cost>

Study Area

Mendocino County is largely rural, home to nearly 90,000 residents spread over 3,878 square miles. The County has four incorporated cities – Ukiah, Willits, Fort Bragg, and Point Arena – of which Ukiah is the largest with a population of 16,036. However, in addition to meeting the needs of its residents, Mendocino County is host to a significant tourism industry, which brings in thousands of visitors each year from outside the County, primarily to the coastal communities. There is also regional travel through the County along US 101 and SR 1. Mendocino County faces the challenge of serving the needs of each of these populations.

There are several major transportation corridors in the County which provide connectivity between local communities and regional destinations. US 101 runs north-south, connecting to Sonoma County and Humboldt County, and serving Ukiah, Willits, and several unincorporated communities including Hopland, Laytonville, and Leggett. SR 1 serves coastal communities including Point Arena, Mendocino, and Fort Bragg, also connecting to Sonoma and Humboldt counties. The other major routes within Mendocino County are SR 128 from US 101 to SR 1 through the Anderson Valley and SR 20 connecting Fort Bragg to Willits. SR 20 and SR 175 also connect the US 101 corridor to communities in Lake County to the east.

In addition to planning for a countywide charging station network, consideration needs to be given to the ability of PEV users to access charging stations once they cross the county line. To ensure this connectivity to a larger regional network, coordination with charging station development in adjacent counties – Sonoma, Humboldt, Lake, Glenn, Tehama, and Trinity – is essential. Sonoma County is by far the most populated of the six, with over 500,000 people, and the City of Santa Rosa (population 175,000) is approximately 35 miles south of the county line. Glenn, Tehama, and Trinity counties, by contrast, have minimal road connectivity to Mendocino County and much lower populations, so development on an intercounty network across these boundaries was not undertaken.

Types of Electric Vehicle Charging Infrastructure

There are three types of electric vehicle chargers, each of which have appropriate uses in accordance with the charging patterns identified in the pyramid that is generally used to characterize electric vehicle charging patterns.

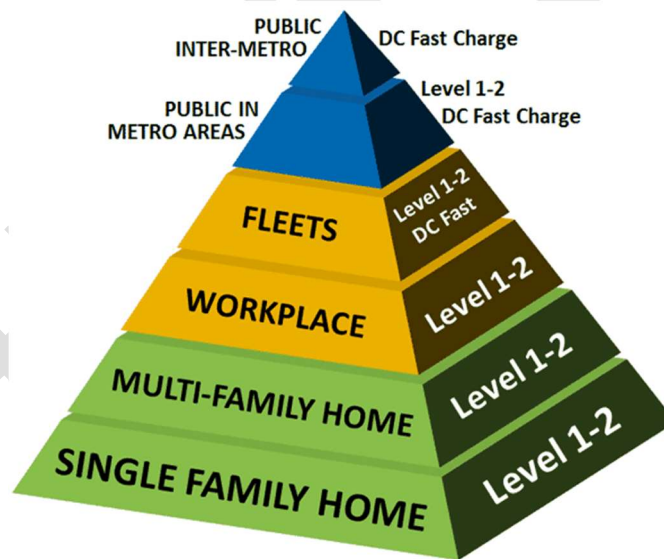

Level 1 charging can be done through a standard 120V outlet. Level 1 charging is the option used by many people for home charging with a gain of approximately 4 miles of range per hour of charging.

Level 2 charging requires 240V and will provide approximately 22 miles of range per hour of charging. Level 2 chargers are the most common type in use for public charging stations serving work places, commercial areas, and other destinations where people are likely to spend one hour or more.

DC Fast Charging is the most expensive charging option in terms of both equipment/installation cost and cost to users but has the advantage of being able to charge up to 80 percent of battery capacity in approximately 30 minutes (range will vary based on battery capacity). As a result, DC fast chargers are the most practical option for

regional and interregional travel. In Mendocino County, a network of DC fast chargers is under construction along the US 101 corridor, and they are being installed at other selected locations as well.

Previous ZEV Planning in Mendocino County

Mendocino County has a long history of supporting development of electric vehicles, with MCOG conducting an initial ZEV feasibility study and demonstration project from 1996 to 1999. Following a period during which electric vehicle development stalled and several models became unavailable, the *2013 Mendocino County Zero Emission Vehicle (ZEV) Regional Readiness Plan* followed up on the recommendations from the 1999 study, developing a countywide strategy to support the development of electric vehicle charging infrastructure. The subsequent *Zero Emission Vehicle (ZEV) Regional Readiness Plan Phase 2 – Feasibility Report*, completed in 2015, advanced implementations of the readiness plan recommendations. The main recommendations of these two plans are described below.

Mendocino County Zero Emission Vehicle (ZEV) Regional Readiness Plan

The Readiness Plan was completed by MCOG with support of the Mendocino County Air Quality Management District. The intent of the Plan was to identify locations that would establish a basic public network of charging stations to provide electric vehicle users in Mendocino County with the confidence to use electric vehicles for travel by minimizing “range anxiety,” which is particularly of concern in rural communities. This basic countywide network falls near the top of the pyramid used to characterize how electric vehicle users charge their vehicles, with home chargers being the dominant means of charging.

The Plan assessed travel patterns and trip purposes to develop an understanding of the travel needs within the County and the potential demand for electric vehicle charging stations. The analysis concluded by establishing a list of 18 priority charging station locations. The locations were identified based on the following criteria:

- Located on the US 101, SR 128, SR 1 or SR 20 corridors
- A standard of 25 miles or less between potential charging site locations, if achievable
- Non-residential locations since EV automakers generally deploy chargers for use at owner’s homes as part of their program
- Located on City, school district, County, State or Federal land such as a post office or other publicly owned property
- Located within walking distance (one-quarter-mile) of a commercial or recreational activity area
- County road right-of-way if other options infeasible
- Connectivity to other jurisdiction station sites
- Number of facilities to be provided based on population
- Availability of dedicated parking spaces

Since it was unlikely that there would be sufficient funding to install all of the locations at once, the locations were prioritized based on the following criteria:

- Completion of stations along a specific State Highway
- Connections to other stations outside of the County, specifically Sonoma County
- Orientation towards tourism traffic
- Placement within the primary population center and related commute routes
- Connecting along the most heavily travelled routes
- Linking to the higher population in the Bay Area to the south
- Interregional connectivity to neighboring counties

The result was a three-phased ranking, generally characterized as: 1) US 101 corridor; 2) connections to Sonoma County and the tourism/winery road corridors, including SR 128 and SR 1; 3) the northern part of the County.

Zero Emission Vehicle (ZEV) Regional Readiness Plan-Feasibility Report

The Feasibility Study followed up on the Readiness Plan by conducting outreach to the public to provide residents with information about efforts to promote adoption of electric vehicles, and to gain input and acceptance of the plan, as well as engage with owners of property that had been identified as sites for the potential location of vehicle charging stations. Five community forums were held – in Point Arena, Ukiah, Fort Bragg, Willits and Boonville – which provided an opportunity to get feedback from the public about the previously identified locations and recommend alternative sites. Property owners and managers were identified and interviewed to determine if they were interested in hosting electric vehicle charging stations and to identify their issues or concerns.

To help advance the implementation of the Readiness Plan, preliminary field reviews were conducted to identify any challenges associated with implementing a charging station on each site and to develop planning level cost estimates.

The 18 sites identified in the Readiness Plan were revised based on the input from the public and responses from property owners. Funding had been secured for stations at two of the sites (which were initially identified in Willits and Boonville, but subsequently changed to Ukiah and Fort Bragg), resulting in a final priority list of 16 sites.

Interregional Alternative Fuels Planning

Electric vehicles are only one element in California's strategy to reduce vehicle emissions from the transportation sector. Accordingly, Mendocino County, in partnership with other northern California counties, has assessed the potential to expand the use of other fuels that offer the potential to reduce carbon emissions as well as other benefits and goals.

Northwest California Alternative Fuels Readiness Project (August 2016)

The Northwest California Alternative Fuels Readiness Project, completed in 2016, was a regional effort covering the Counties of Del Norte, Siskiyou, Humboldt, Trinity, and Mendocino. From the Executive Summary: [The project] "was launched to develop strategies for the deployment of alternative fuel infrastructure, and identify activities to encourage the adoption of alternative fuel vehicles in rural, northwest California..." Alternative fuels considered in the Plan were biodiesel, electricity, ethanol, hydrogen, natural gas, renewable natural gas, propane, and renewable diesel.

To support the advancement and adoption of alternative fuel vehicles across the five participating counties, this effort concluded with a list of 69 action steps, grouped into the following four categories:

1. Market development actions, funding mechanisms, and incentive programs
2. Land use, zoning, and permitting changes
3. Safety, first responder, and auto support industry training
4. Outreach and promotion

While electric vehicles were determined to be the most cost-effective option when considering the cost of vehicles, infrastructure, and operations, the project report concluded that a regional approach using a range of fuels and technologies would be needed to meet carbon emissions reduction goals. Regarding the portion of the greenhouse gas emissions reduction strategy focused on electric vehicles, a simulation concluded that the least-cost scenario would include installation of 20,000 home electric vehicle charging stations and 339 public stations across the five counties. In the near term, the analysis identified fleet vehicles as providing the best opportunity for adopting other alternative fuels in Mendocino County, given the lack of publicly available infrastructure for options other than electric vehicles. Fleet users operating locally can return to the same fueling station each day and therefore are viable even without the implementation of a network of stations.

To guide the implementation of the recommended steps to implement the Plan, it was recommended that the partner agencies establish a regional Clean Cities Coalition. The Coalition would help to ensure coordination across the region in addressing a wide range of issues, including funding, land use and development regulations, as well as marketing and promotion of alternative fuels. The U.S. Department of Energy's Clean Cities program provides technical assistance and other resources. Such coalitions are helping to guide the development of alternative fuels infrastructure throughout California and in other states.

North Coast and Upstate Fuel Cell Vehicle Readiness Project

The *North Coast and Upstate Fuel Cell Electric Vehicle (FCEV) Readiness Project* focused on preparing eight of California's northernmost counties – Del Norte, Siskiyou, Humboldt, Trinity, Shasta, Mendocino, Tehama, and Glenn – for the introduction of fuel cell vehicles, which are powered by hydrogen. Building on the work completed through the Northwest California Alternative Fuels Readiness Project, this effort was undertaken to coordinate efforts in these counties plan the development of hydrogen fueling infrastructure, and foster a market for FCEVs.

The first task of this planning effort identified key regional hydrogen hot spots to determine where anchor sites should be located. These hot spots were identified by using a set of qualitative criteria to compare the five census-designated micro- or metropolitan statistical areas within the project region. These areas were evaluated based on proximity to major corridors, distance from existing FCEV markets, consistency with the Federal Highway Administration's Alternative Fuel Corridor designation, and level of future hydrogen demand identified through the California Hydrogen Infrastructure Tool (CHIT) model².

To address the potential adoption of fuel cell technology in Mendocino County, MCOG staff participated in the project. At the conclusion of the project, MCOG staff prepared recommendations regarding the appropriate development of fuel cell technology as part of a broader alternative fuels strategy in Mendocino County. Generally, given the rural character of Mendocino County and the high cost and lack of developed fuel cell infrastructure, it was determined that fuel cells offer near-term potential as a fuel source for public and private fleet operators rather than the general public. In developing their recommendations, MCOG solicited input from key fleet operators that were prioritized based on size, partnerships, commitment to alternative fuels, and other criteria. These operators included the Mendocino Transit Authority, County of Mendocino, and the Mendocino County Air Quality Management District.

In addition, MCOG staff's subsequent report regarding the project indicated that uses such as back-up energy storage or emergency power generators may be a more practical opportunity in the Mendocino County region and should be explored first. Further development of fuel cells for these applications could lay the groundwork for broader use by consumers in the future. Additional recommendations to advance the use of fuel cell technology included training and education for MCOG's ZEV advisory group (ZAG) stakeholders and fleet operators, while focusing on fleets in developing future FCEV fueling infrastructure.

Regarding the potential for consumer use of alternative fuel vehicles, MCOG recommended continued focus on the development and adoption of electric vehicles, which are further along in development and offer a more viable transportation alternative for more consumers in Mendocino County.

Goal

For battery electric and plug-in hybrid vehicles to be a viable alternative to gasoline-powered vehicles in Mendocino County for local, regional, and interregional travel, there will need to be a comprehensive network of plug-in electric vehicle charging stations within the county as well as the ability to access nearby charging stations in adjacent counties and regions. The goal of the *Mendocino County Regional Readiness Plan Update* is to establish a framework that will support development of a countywide PEV charging station network through the following steps:

1. Recommending policies that agencies can adopt to facilitate charging station development and minimize barriers to implementation of the electric vehicle charging station network.
2. Coordinating efforts of public agencies and private sector partners to fund and develop a Core Network of public electric vehicle charging stations throughout Mendocino County for residents, visitors, and through travelers.
3. Supporting and encouraging the development of privately funded electric vehicle charging infrastructure based at employment sites, shopping and commercial destinations, and other locations.
4. Establishing a mechanism to pursue ongoing collaboration among regional stakeholders to promote coordinated planning and application of best practices to support the buildout of the network.
5. Supporting efforts to increase adoption of electric vehicles in the context of regional strategies being undertaken for all alternative fuel vehicles, as identified in the Northwest California Alternative Fuels Readiness Project and future alternative fuels planning efforts.

Key Stakeholders

The planning and implementation of alternative fuels infrastructure requires collaboration of numerous public agencies and private sector partners. For the 2013 Plan and 2015 feasibility report, a ZEV Advisory Group (ZAG) was convened to provide guidance and ongoing feedback to MCOG staff and the consultants. The ZAG was reconstituted in 2019 to take on a similar role in this Update and met four times during the planning process.

Participants in the ZAG and other stakeholders included representatives of MCOG, Mendocino County Air Quality Management District, County of Mendocino, City of Ukiah, City of Willits, City of Fort Bragg, City of Point Arena, Caltrans District 1, and ChargePoint. While these are the primary entities that will be involved in the implementation of the core public network within Mendocino County, there will be numerous other stakeholders that will play important roles in the remainder of the network. This includes property owners of charging station sites, employers, business owners, staff from adjacent jurisdictions, and community-based organizations, as discussed in the Implementation chapter.

Travel Patterns and Electric Vehicle Ownership

A primary consideration in selecting electric vehicle charging station locations is current and anticipated travel patterns in the County of electric vehicle owners. Travel needs are largely a function of the population distribution, the location of jobs, the number and distribution of electric vehicle owners, and characteristics of the road network. This section of the plan assesses these factors.

Mendocino County Characteristics

Mendocino County Population and Employment

The U.S. Census Bureau’s American Community Survey (ACS) provides updates to the nationwide demographic dataset annually, between decennial Census efforts. The ACS data is collected using a survey of a statistically significant subset of the population to develop one-year demographic estimates. These one-year estimates are aggregated up to five-year estimates to further decrease the margin of error. The ACS five-year estimates are a reasonably accurate representation of the nation’s demographic data between decennial Census counts.

Based on the 2017 ACS five-year data, approximately 18 percent of the County’s population resides within the City of Ukiah city limits. The total population of the County is estimated at 87,497 persons. The ACS data for Ukiah, Fort Bragg, Willits, and the rest of the County are summarized in Table 1.

	Ukiah	Fort Bragg	Willits	Rest of County	Total
Total Population	15,917 (18%)	7,269 (8%)	4,844 (6%)	59,497 (68%)	87,497

Source: U.S. Census American Community Survey, 2017 5-Year Estimates, Table S0101

The U.S. Census Bureau’s “OnTheMap” tool is a web-based mapping and reporting application built to query the 2002 – 2015 LEHD Origin Destination Employment Statistics (LODES) dataset. OnTheMap shows where workers live and are employed and can be used to map travel patterns of workers and identify employment centers.

Based on the OnTheMap data from 2015, the latest dataset available, approximately one-third of all workers in Mendocino County are employed within the Ukiah city limits. The OnTheMap data for Ukiah, Fort Bragg, Willits, and the rest of the County are summarized in Table 2.

	Ukiah	Fort Bragg	Willits	Rest of County	Total
Total Employment	9,079 (33%)	3,447 (13%)	2,307 (9%)	12,277 (45%)	27,110

Source: U.S. Census OnTheMap 2015 Primary Jobs for Mendocino County

Countywide Vehicle Ownership Statistics

The California Department of Motor Vehicles (DMV) Information Services Branch compiles vehicle registration data annually and reports the total number of vehicles registered by geographic area. The data is reported at the County, City, and Zip Code levels. The most recent dataset available for all jurisdictions in Mendocino County is from January 2018.

Mendocino County has proportionally more diesel-powered vehicles and fewer gasoline powered vehicles than the rest of state. Electric vehicles are also underrepresented, as PEVs make up approximately 1.1 percent of the statewide vehicle fleet, but only 0.7 percent of the vehicle fleet in the County. The type of electric vehicles in Mendocino County also differs from the state as a whole, as there are more plug-in hybrid vehicles than battery electric vehicles. Given the rural character of the County and the relatively small number of public charging stations available, this is to be expected as drivers seek reliable vehicle charging opportunities. These statistics are summarized in Table 3.

Table 3 – Vehicle Ownership in Mendocino County versus Statewide as of January 2018

Vehicle Type	Mendocino County		Statewide	
	Number of Vehicles	Percentage of Total	Number of Vehicles	Percentage of Total
All Vehicles	92,165	100.0%	30,581,168	100%
Gasoline	75,246	81.6%	26,196,359	85.6%
Diesel	9,351	10.1%	1,225,645	4.0%
Plug-in Electric	651	0.7%	341,939	1.1%
<i>Battery Electric</i>	237	0.3%	178,348	0.6%
<i>Plug-in Hybrid</i>	414	0.4%	163,591	0.5%
Other Vehicles	6,917	7.6%	2,817,225	9.3%

Source: State of California Department of Motor Vehicles Information Services

The distribution of plug-in electric vehicles is generally in line with the population distribution although there are some notable variations. The City vehicle registration data shows that approximately one-third of all vehicles registered in Mendocino County are registered in Ukiah. Additionally, approximately one-third of the battery electric PEVs are registered in Ukiah. More plug-in hybrid PEVs are registered in Fort Bragg compared to the other cities reviewed. Less than 10 percent of the battery electric PEVs in the County are registered in Willits as compared to 15 percent of all vehicles. Despite the low population density, residents in areas of the County outside of the three largest cities have disproportionately higher electric vehicle ownership. The City-level vehicle ownership data is summarized in Table 4.

Table 4 – Electric Vehicle Ownership by City in Mendocino County as of January 2018

	Ukiah	Fort Bragg	Willits	Rest of County	Total
All Vehicles	29,146 (31%)	13,989 (15%)	13,535 (15%)	35,495 (39%)	92,165
Plug-in Electric	142 (21%)	135 (21%)	63 (9%)	310 (51%)	651
<i>Battery Electric</i>	71 (30%)	43 (18%)	22 (9%)	101 (43%)	237
<i>Plug-in Hybrid</i>	71 (17%)	92 (22%)	42 (10%)	209 (51%)	414

Source: State of California Department of Motor Vehicles Information Services

Assessment of Existing Infrastructure

Field reviews were conducted to evaluate the characteristics of existing charging station sites in Mendocino County. As chargers have been installed over a number of years, and the standards and regulations are still relatively new, there is considerable inconsistency, which can potentially lead to confusion among users as well as challenges in accessing the chargers. The following section documents the conditions that were observed at the existing charging stations.

DC Fast Chargers

Direct-current (DC) fast chargers enable rapid charging along heavily traveled corridors, often located at “station,” and run on 208-volt or 480-volt three-phase electrical service. DC fast chargers can provide between 60 and 80 miles of added range per 20 minutes of charging time. There are three types of DC fast charging connectors, or ports, J1772 Combo, CHAdeMO, and Tesla. The J1772 Combo connector is used by Chevrolet and BMW and can be used at all power level of chargers. The CHAdeMO connector is used by Nissan, Mitsubishi, and Toyota and is the most common DC fast charging connector. The Tesla connector is unique to Tesla vehicles and works at all power levels of Tesla-specific chargers, including their proprietary DC fast charger called a “Supercharger.”

There is one DC fast charger located at Greenwood Ridge Vineyards in Philo intended for guest use only during vineyard business hours. Guests must see the front desk for access. At the Municipal Parking Lot E in the City of Ukiah, there are eight public Tesla Superchargers available 24 hours daily. The nearest DC fast chargers outside of Mendocino County are located in Windsor (Sonoma County), Williams (Colusa County), and Loleta (Humboldt County).



Plate 1 Greenwood Ridge Valley DC fast charger in Philo



Plate 2 Tesla Superchargers in a City Ukiah parking lot

Level 2 Chargers

A Level 2 charger runs on alternating-current (AC) 240-volt or 208-volt electrical service. Level 2 chargers provide between 10 and 25 miles of range per hour of charging time. There are two types of Level 2 charger connectors – the J1772 and the Tesla. The J1772 connector can be used by all commercially available PEVs, including Tesla vehicles, when using a proprietary adaptor. The Tesla Level 2 chargers with the Tesla proprietary connector can only be used by Tesla vehicles. There are 44 J1772 connectors at 29 locations throughout Mendocino County. There are 31 Tesla connectors at 18 locations throughout Mendocino County. Examples of these chargers are shown in Plates 3 through 18.



Plate 3 Level 2 charger in Elk at the Greenwood State Beach



Plate 4 Level 2 charger at a hotel in Fort Bragg



Plate 5 Level 2 chargers at the Boatyard Shopping Center



Plate 6 Level 2 charger at the Cabrillo Lighthouse State Park



Plate 7 Level 2 charger at Russian Gulch State Park



Plate 8 Level 2 charger in Point Arena



Plate 9 Level 2 charger at Handley Cellars in Philo



Plate 10 Level 2 charger in Hopland

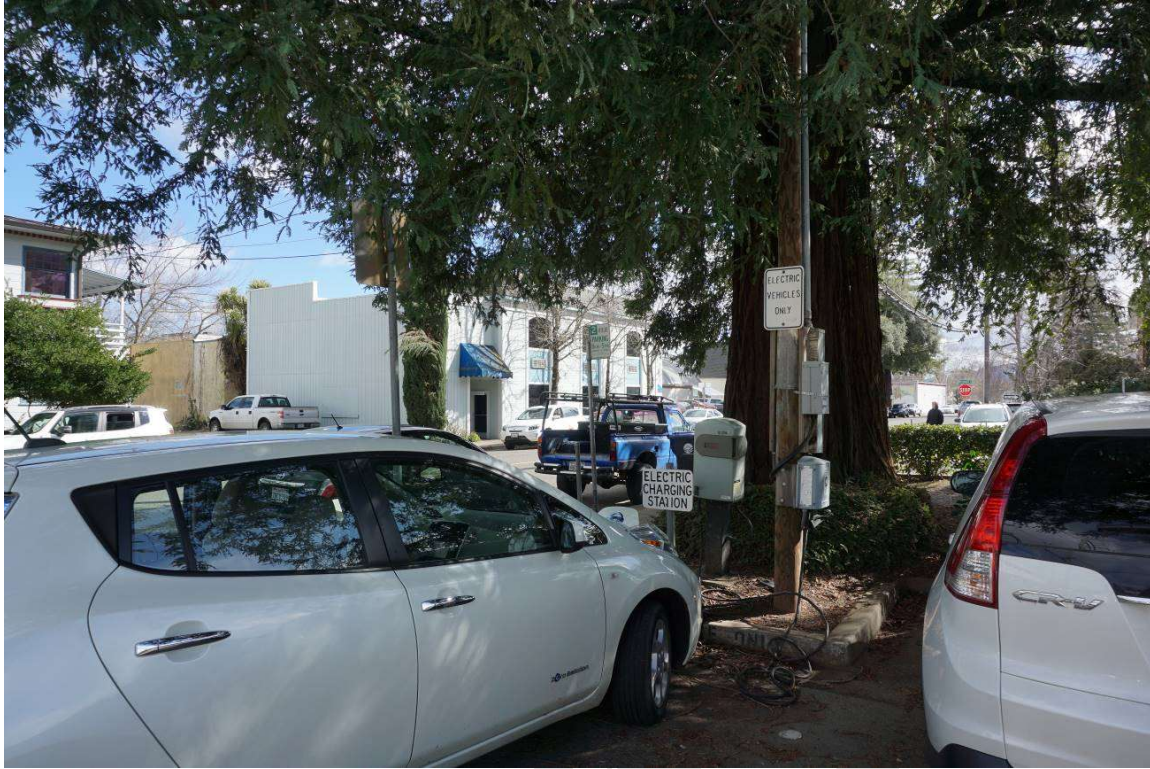

Plate 11 Level 2 charger in City of Ukiah parking lot



Plate 12 Level 2 charger in the Costco parking lot in Ukiah



Plate 13 Level 2 chargers at Super 8 Motel in Ukiah



Plate 14 Level 2 chargers in City of Willits parking lot



Plate 15 Tesla Level 2 chargers in Fort Bragg



Plate 16 Tesla Level 2 chargers in Philo



Plate 17 Tesla Level 2 charger in Hopland

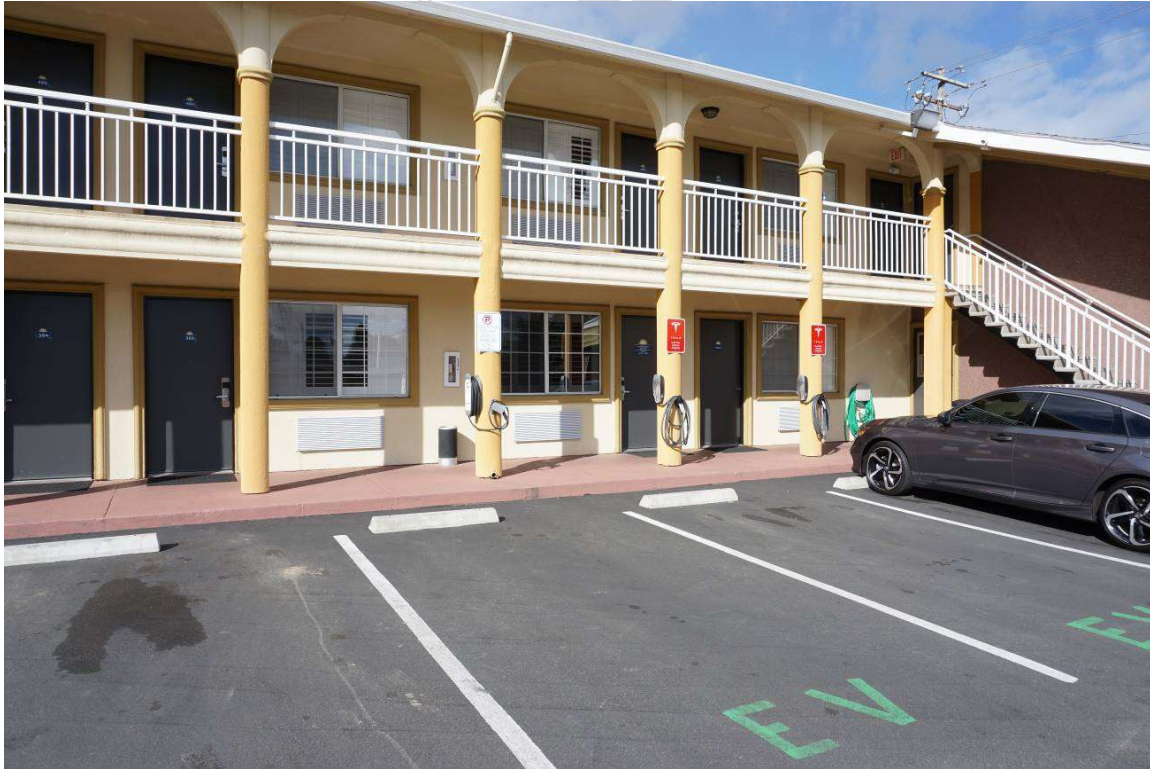

Plate 18 Level 2 chargers at a hotel in Ukiah

Level 1 Chargers

AC Level 1 chargers provide PEVs with the ability to charge via a standard 120-volt electrical source. Level 1 chargers provide between 2 and 5 miles of range per hour of charging. The standard connector for a Level 1 charger is a J1772 connector. These connectors are plugged directly into a common three-prong household plug. Level 1 chargers are typically used by PEV owners for home-based charging, but there are currently eight public Level 1 connectors at six locations in Mendocino County.

Accessibility

While a detailed accessibility assessment was not conducted as part of this evaluation, there are numerous charging stations that do not meet current requirements such as providing access aisles and an accessible path of travel. The California Building Code accessibility requirements for electric vehicle charging stations has only been in effect since January 1, 2017, so this is particularly an issue for older charging stations. For information on meeting accessibility requirements, see Appendix A.

General Field Visit Observations

As shown in the Plates above, there is a wide variety of signage and striping used at electric vehicle charging stations throughout Mendocino County. More recently-installed charging infrastructure, such as the Level 2 chargers in Willits at the city parking lot, are some of the newest in the County and therefore meet the requirements of the *California Manual on Uniform Traffic Control Devices for Streets and Highways*, California Department of Transportation, 2014. In contrast, some charging locations at hotels are missing all signage and striping. While it is outside the scope of this project to recommend specific improvements to existing infrastructure, going forward, local jurisdictions should review proposed installations for CA MUTCD compliance.

Recommended PEV Charging Station Network

As indicated in the charging pyramid diagram in the first section of this Plan, public electric vehicle charging is not intended to be a primary charging location. Rather it is intended to decrease “range anxiety” and increase the useful range of electric vehicles during daily life. Public charging stations are installed at locations where vehicles are highly concentrated, such as shopping centers, city parking lots and garages, airports, hotels, government offices, and other businesses. An assessment of the range provided by the existing charging network was conducted to help identify locations where additional charging infrastructure is needed.

The analysis focused on Level 2 charging stations, which make up a majority of public chargers. Level 2 chargers provide, on average, 22 miles of range per hour of charge. Since the average driver in California travels 25 miles a day, Level 2 chargers are more than sufficient for daily trips. While DC fast chargers can provide more range per hour they are considerably more expensive to purchase, install, and maintain. Level 2 chargers can have a very small footprint while providing the same number of charging ports. With the shorter charging time required, the DC fast charger network has largely been targeted toward meeting the needs of inter-regional travelers.

While all “public” Level 2 chargers were included in this analysis, a more detailed review of the charging stations was conducted to account for the varying levels of access that each charger offers to electric vehicle owners. Public chargers are identified by the U.S. Department of Energy’s Alternative Fuel Data Center (DOE AFDC), which maintains a publicly accessible list of alternative fueling infrastructure nationwide (<https://afdc.energy.gov/>) that are hosted by public agencies as well as private businesses. While these chargers are available for use by the general public, the degree to which a particular electric vehicle owner can use a specific charger at any given time depends on the following factors:

1. Connector standards: Level 2 charging stations can be open standard (J1772 connector) or proprietary. Notably, Tesla chargers (which make up a significant portion of the chargers in Mendocino County) can only be used by Tesla vehicles due to their use of proprietary connectors.
2. Time of day: Charger access may be time-restricted by the station host.
3. Host permission: Some privately-owned charging stations can only be used by patrons of the host business. This is especially the case at chargers that have been installed by hotels for the benefit of their customers. In some cases, non-customers can use these chargers for a fee.

The intent of this Plan is to develop a “Core Network” that would provide a basic level of charging for the broadest possible number of PEV users. Therefore, for the purposes of identifying recommended Core Network sites, only the public chargers meeting the following criteria were included in this analysis:

- Level 2
- Open Standard (J1772 connectors)
- Available 24 hours per day, seven days per week
- Do not require patronage of a business

This subset of public charging stations is referred to in this Plan as “open access” chargers. To provide a broader view of the availability of charging infrastructure, the analysis below separately considers the range coverage provided by public chargers that do not meet these criteria.

Geographic Connectivity of Public Charging Station Network

The location of the electric vehicle charging infrastructure for Mendocino County and the neighboring counties was downloaded from the DOE AFDC. The list of charging stations was reviewed by the ZAG and local municipal staff and additional charging locations missing from the DOE AFDC list were incorporated. The data was then

mapped using the geographic information system (GIS) program ArcMap, which enables the distance from a charging station to be measured as actual travel distance along the road network, rather than as a straight-line buffer. The overall geographic distribution shows that stations are primarily clustered in the SR 1 corridor coastal communities and the US 101 corridor, with some additional chargers available along SR 128 in the Anderson Valley.

To demonstrate geographic connectivity of the charging station network, ArcMap's Network Analysis Toolkit was utilized to develop "travel contours." These travel contours represent the approximate distance an electric vehicle can drive after charging for one hour. For a Level 2 charger, the average electric vehicle can add 22 miles of range per hour of charge. For a DC fast charger, by contrast, the average electric vehicle can add 100 miles of range per hour of charge. It is noted that the actual distance travelled on a charge varies depending on several factors that influence a vehicle's battery use, including speed, driving style, terrain, temperature, and use of air conditioning. These travel contours follow the roadway network in Mendocino County and connect to the roadway networks in the neighboring counties.

DC Fast Chargers

The DC fast charger travel contour map includes the existing fast chargers in Philo and Ukiah as well as the chargers that have been funded or are under construction as part of the US 101 Corridor project. These chargers support inter-regional travel and are located approximately every 50 miles along US 101. In Mendocino County chargers are planned in Hopland, Ukiah, Willits, Laytonville, and Leggett. The one-hour charging travel contours, as shown in Map 1, extend along nearly every major roadway in the County, with the exception of US 1 near Gualala. The DC fast chargers in Mendocino County would allow electric vehicle owners to reach the major tourist destinations where they could recharge using other charging infrastructure.

All Public Level 2 Chargers

The analysis of the entire Level 2 charging network included two travel contours, a one-hour and a two-hour, buffer. The one-hour buffer extends 11 miles from the existing charging stations, representing a 22-mile round trip. The two-hour buffer extends 22 miles from the existing charging stations, representing a 44-mile round trip. The 2013 ZEV Plan and 2015 Feasibility Study looked to locate charging stations approximately 25 miles apart, which would ensure that owners would be able to make it to a charging station if they are running low on battery power. The existing Level 2 charging network, including open access locations, as summarized in Table 5 and proprietary locations, as summarized in Table 6, provides complete coverage along the US 101 corridor between the Sonoma County line and Willits, along US 1 from Gualala to Fort Bragg, and along SR 128 between SR 1 and Boonville, as shown in Map 2. The one-hour contours do not connect the US 101 and the SR 1 corridors across SR 20 and SR 128; however, the two-hour contours do provide complete connectivity between the corridors.

Level 2 Open Access Chargers

The analysis of the open access Level 2 charging network employed the same travel contours. As can be seen in Map 3, a reduced level of connectivity is provided in comparison to the full network of public chargers assessed in Map 2. There are geographic connectivity gaps in the one-hour contours along US 101 between Willits and Ukiah and between Ukiah and the Sonoma County line. Connectivity remained the same along the SR 1 and SR 128 corridors. The same east-west gaps exist across SR 20 and SR 128.

Table 5 – Level 2 Open Access Chargers

Station Name	City	Access Type	Level 2 Chargers	Other Chargers	Notes
Greenwood Ridge Vineyards	Philo	Limited	1	1 (DC fast)	
Caspar Community Center	Caspar	Full	2	2 (Level 1)	
Greenwood State Beach	Elk	Full	2		
Beachcomber Motel and Spa	Fort Bragg	Limited	1		
Boatyard Shopping Center	Fort Bragg	Full	2		ChargePoint Network
MacKerricher State Park	Fort Bragg	Full	2	2 (Level 1)	
City Hall parking lot	Fort Bragg	Full	2		ChargePoint Network
Public parking lot	Fort Bragg	Full	2		ChargePoint Network
Van Damme State Park	Little River	Full	2		
Little River Inn	Little River	Full	1		
Mendocino Inn & Spa	Little River	Limited	1		
Stanford Inn by the Sea	Mendocino	Limited	2		
Point Cabrillo Light Station State Historic Park	Mendocino	Full	2	2 (Level 1)	
Sea Rock Inn	Mendocino	Limited	1		
MacCallum House Inn	Mendocino	Limited	1		
Russian Gulch State Park	Mendocino	Limited	1	2 (Level 1)	
Coast Guard House Historic Inn & Cottages	Point Arena	Limited	1		
Point Arena	Point Arena	Full	2		ChargePoint Network
Westport Union landing State Beach	Westport	Full	2	2 (Level 1)	
Hendy Woods State Park	Philo	Full	2	2 (Level 1)	
EV Charging Station	Philo	Full	2		ChargePoint Network
The Bewildered Pig	Philo	Full	1		
Terra Savia Winery	Hopland	Limited	1		
Public Parking Lot	Ukiah	Full	1	1 (SP Inductive)	
Super 8	Ukiah	Limited	1		
Caltrans - District 1	Ukiah	Limited	1		
Best Western - Orchard Inn	Ukiah	Limited	1		
City of Willits	Willits	Full	2		ChargePoint Network
City of Willits	Willits	Full	2		ChargePoint Network

Table 6 – Level 2 Proprietary Public Chargers

Station Name	City	Access Type	Level 2 Chargers	Notes
Elk Cove Inn & Spa	Elk	Limited	1	Tesla Destination
Beachcomber Motel & Spa on the Beach	Fort Bragg	Limited	1	Tesla Destination
Ocean View Lodge	Fort Bragg	Limited	2	Tesla Destination
Dennen's Victorian Farmhouse	Little River	Limited	1	Tesla Destination
Little River Inn	Little River	Limited	1	Tesla Destination
Mendocino Inn & Spa	Little River	Limited	2	Tesla Destination
The Stanford Inn by the Sea	Mendocino	Limited	2	Tesla Destination
Sea Rock Inn	Mendocino	Limited	2	Tesla Destination
Agate Cove Inn	Mendocino	Limited	2	Tesla Destination
MacCallum House	Mendocino	Limited	4	Tesla Destination
The Bewildered Pig	Philo	Limited	1	Tesla Destination
Greenwood Ridge Vineyards Tasting Room	Philo	Limited	1	Tesla Destination
Real Goods Solar Living Center	Hopland	Full	2	Tesla Destination
Terra Savia Winery	Hopland	Limited	2	Tesla Destination
Municipal Parking Lot E	Ukiah	Full	*	Tesla Destination
Best Western - Orchard Inn	Ukiah	Full	2	Tesla Destination
Super 8	Ukiah	Full	2	Tesla Destination
Days Inn	Ukiah	Full	2	Tesla Destination
The Old West Inn	Willits	Limited	1	Tesla Destination

Notes: *Eight DC Fast Chargers available

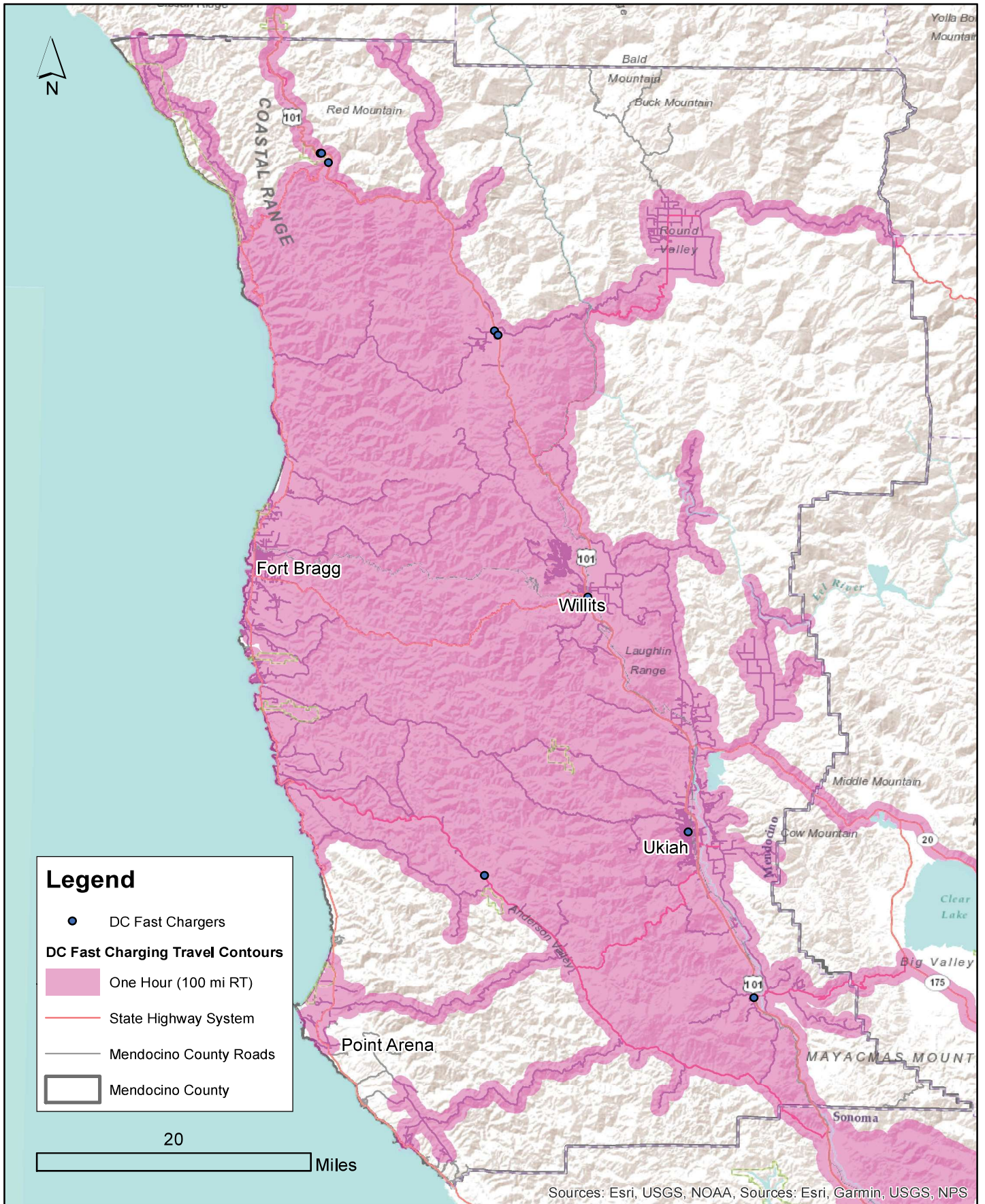

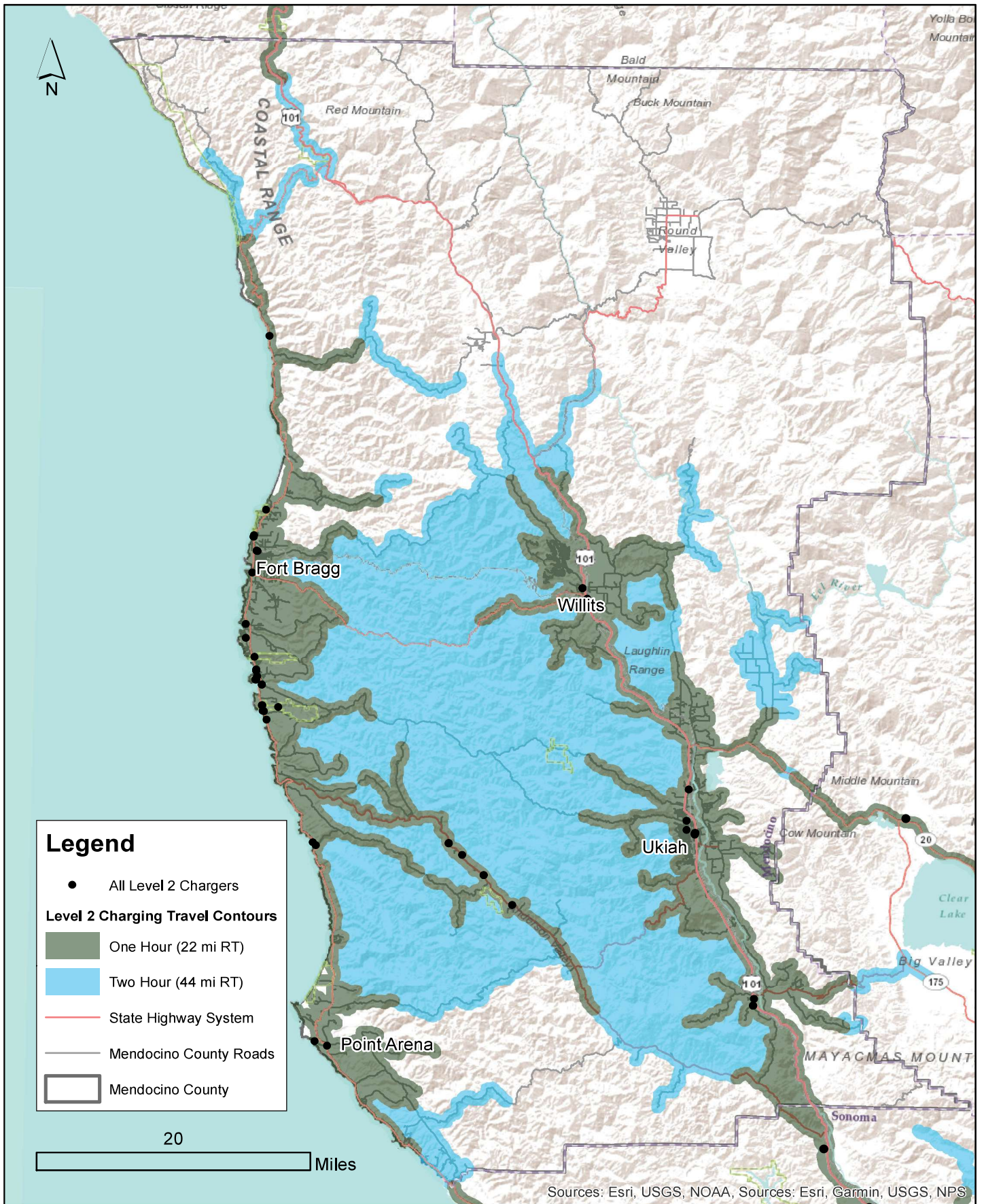

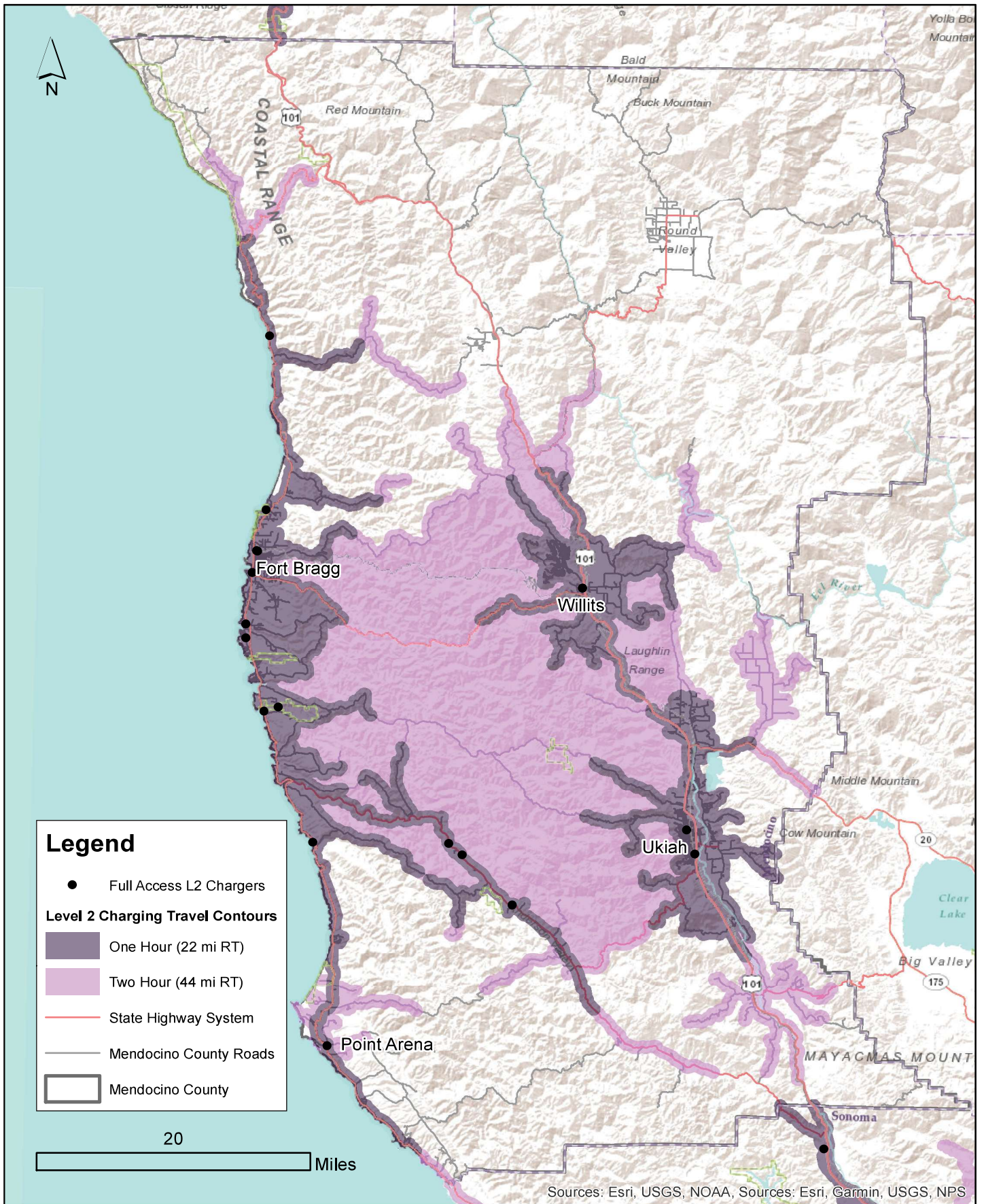

Recommended Core Network Locations

The recommended electric vehicle charging station Core Network for Mendocino County represents a basic level of Level 2 charging infrastructure intended to provide a greater level of certainty to PEV owners that they will maintain access to charging stations for travel within Mendocino County and to adjacent jurisdictions. The Core Network is limited to open access stations. The locations were selected to minimize gaps in the network's geographic coverage and enhance charging station capacity in areas of high demand. It should be emphasized that the Core Network represents only a portion of the overall charging station network to be developed, as it is anticipated that the majority of charging stations will be implemented at workplaces, by business owners, and by homeowners. However, the identification of the Core Network can help guide the efforts of public agencies and other stakeholders in future efforts to plan and secure EVCS funding.

The Core Network includes the following three types of sites:

1. Priorities identified in the 2013 ZEV Plan and Feasibility Study;
2. Locations that would eliminate gaps in charging station connectivity throughout the County; and
3. Locations where current capacity of charging stations has not kept pace with demand.

The priority locations from the 2013 ZEV Plan and 2015 Feasibility Study emerged from an extensive outreach and evaluation process, including contacting property owners, input from the public, and a preliminary site evaluation. The recommended Core Network locations have not been identified at the parcel level as site investigation and outreach to property owners is needed. However, at this general level these locations meet the need for improved Level 2 charger connectivity throughout the county and would enable the network to better serve the anticipated charging station demand.

Estimate of Future Charging Station Demand

The California Energy Commission (CEC), working in partnership with the National Renewable Energy Laboratory (NREL), developed the Electric Vehicle Infrastructure Projection (EVI-Pro) simulation tool to estimate the future demand for electric vehicle charging stations at the statewide and county level². This estimate was based in part on California state goals for electric vehicle adoption as well as current PEV ownership rates and the driving and charging patterns of electric vehicle owners. Projecting future demand for electric vehicles is highly imprecise, particularly given the rapidly evolving electric vehicle technology and pricing structure. This highlights the need to continue to update planning on a regular basis. In terms of identifying appropriate locations for charging stations, demand and travel patterns are largely dependent on land use and are unlikely to change significantly. However, the quantity of charging stations needed at each location will change as PEVs become more widely adopted.

Recommended Number of Charging Stations by Location

While the geographic connectivity analysis provides guidance for charging station locations to address range anxiety concerns, the Core Network is also intended to serve the current and future demand. Already other parts of California with high PEV adoption rates have experienced challenges due to the insufficient capacity at public charging stations, requiring drivers to wait for an available port. Given the amount of time required for Level 2 charging, this lack of capacity could be a significant barrier to many people purchasing electric vehicles.

Recommendations were developed for this plan relative to the number of chargers needed at locations throughout the County based on the CEC's County-level demand projections as well as local employment levels. The allocation of chargers to each location was tied to employment rather than population since the demand for

² *California Plug-In Electric Vehicle Infrastructure Projections: 2017-2025*, California Energy Commission, March 2018.

the Core Network Level 2 charging will be highest in the areas of greatest activity; home chargers will already be available for meeting the charging needs of PEV owners at their place of residence. Table 7 indicates the distributions of vehicle registrations and jobs in Mendocino County's three largest cities – Ukiah, Willits, and Fort Bragg – and the remainder of the county. The employment levels are closely aligned with the number of battery electric vehicles registered in those areas, highlighting the need for charging stations at these locations. The distribution of plug-in hybrid vehicles is quite different, as their ownership is considerably higher in the more rural areas. This is to be expected, as hybrid vehicles provide greater flexibility for vehicle owners, as they can use gasoline and are less reliant on the availability of charging stations.

Table 7 – Mendocino County Vehicle Registrations, Population, and Employment

Location	Share of County Population (%)	Share of County Employment (%)	Vehicle Registrations (% of countywide total)		
			All Vehicles	Battery Electric Vehicles	Plug-In Hybrid Electric Vehicles
Ukiah	18	33	31	30	17
Fort Bragg	8	13	15	18	22
Willits	6	9	15	9	10
Remainder of County	68	45	39	43	51

Sources: CA DMV, US Census

The CEC estimated that the demand in 2025 for public electric vehicle charging stations in Mendocino County would be approximately 150 stations/ports. Based on the distribution of jobs across the County, approximately 33 percent of the chargers should be in Ukiah, 13 percent should be in Fort Bragg, nine percent in Willits, and the remaining charging stations should be located near public destinations throughout other areas of the County. This leads to the following targets for the number of Level 2 public charging ports by 2025:

- Ukiah – 50
- Fort Bragg – 20
- Willits – 14
- Other – 66

Based on the number of existing charging ports in the County, approximately 75 additional Level 2 public charging ports need to be installed by 2025 to meet the estimated demand. The previously identified host locations from the 2013 ZEV Plan and 2015 Feasibility Study account for 30 of the additional charging ports, assuming two ports at each of the 15 locations. This leaves 45 additional charging stations to meet the anticipated 2025 demand. This is summarized in Table 8.

Table 8 – Existing and Proposed Chargers by Location

Location	Existing Open Access Level 2 Chargers	Other Existing Level 2 Chargers	Total Existing Level 2 Chargers	Public Level 2 Chargers – 2025 Goal	Chargers Needed to Meet 2025 Goal
Ukiah	4	6	10	50	40
Fort Bragg	9	3	12	20	8
Willits	4	1	5	14	9
Remainder of County	27	21	48	66	18
Total	44	31	75	150	75

Geographic Distribution of New Electric Vehicle Charging Stations

As shown in Map 4, the geographic connectivity analysis of all the planned and proposed locations demonstrates nearly continuous coverage of the one-hour travel contours. Three gaps remain at relatively remote locations along major travel routes: 1) US 101 between Willits and Laytonville, 2) US 101 between Laytonville and Leggett, and 3) SR 1 north of Rockport; however, these gaps are within both the two-hour Level 2 charger travel contour as well as the one-hour DC fast charger network. Particularly along US 101, it is unlikely that drivers would be willing to spend the time required for Level 2 charging at such remote locations. One area not previously addressed in planning for electric vehicle infrastructure is Covelo, which has been included on the list of recommended charger locations.

Level 2 Charger Core Network

The recommended Core Network charging station locations are included in Table 9. While the addition of charging stations in Covelo eliminates a connectivity gap in the one-hour travel contour, the other locations added in the current plan were included to address an imbalance in the existing charging station infrastructure and the existing and anticipated demand for Level 2 charging. While general guidance has been provided regarding the total number of stations to be installed in these areas, the number of chargers to be located at a specific site will need to be determined in the site selection process. While most stations in Mendocino County have two charging ports, there are larger installations such as the eight Tesla superchargers in downtown Ukiah. There can be significant economies of scale associated with clustering several chargers together by saving on the costs of connecting to a power source, providing accessibility in accordance with the state requirements, completing the required paving and striping work, etc. Hosting multiple ports at a single location can also provide users with greater confidence that a port will be available at any given time.

Shown are Level 2 EVSE one hour and two hour travel contours to highlight the geographic coverage of the charging network in Mendocino County. The Planned Open L2 Sites have been previously studied and identified as specific locations. The Proposed Open L2 Sites are geographic areas where the need for additional chargers has been identified.

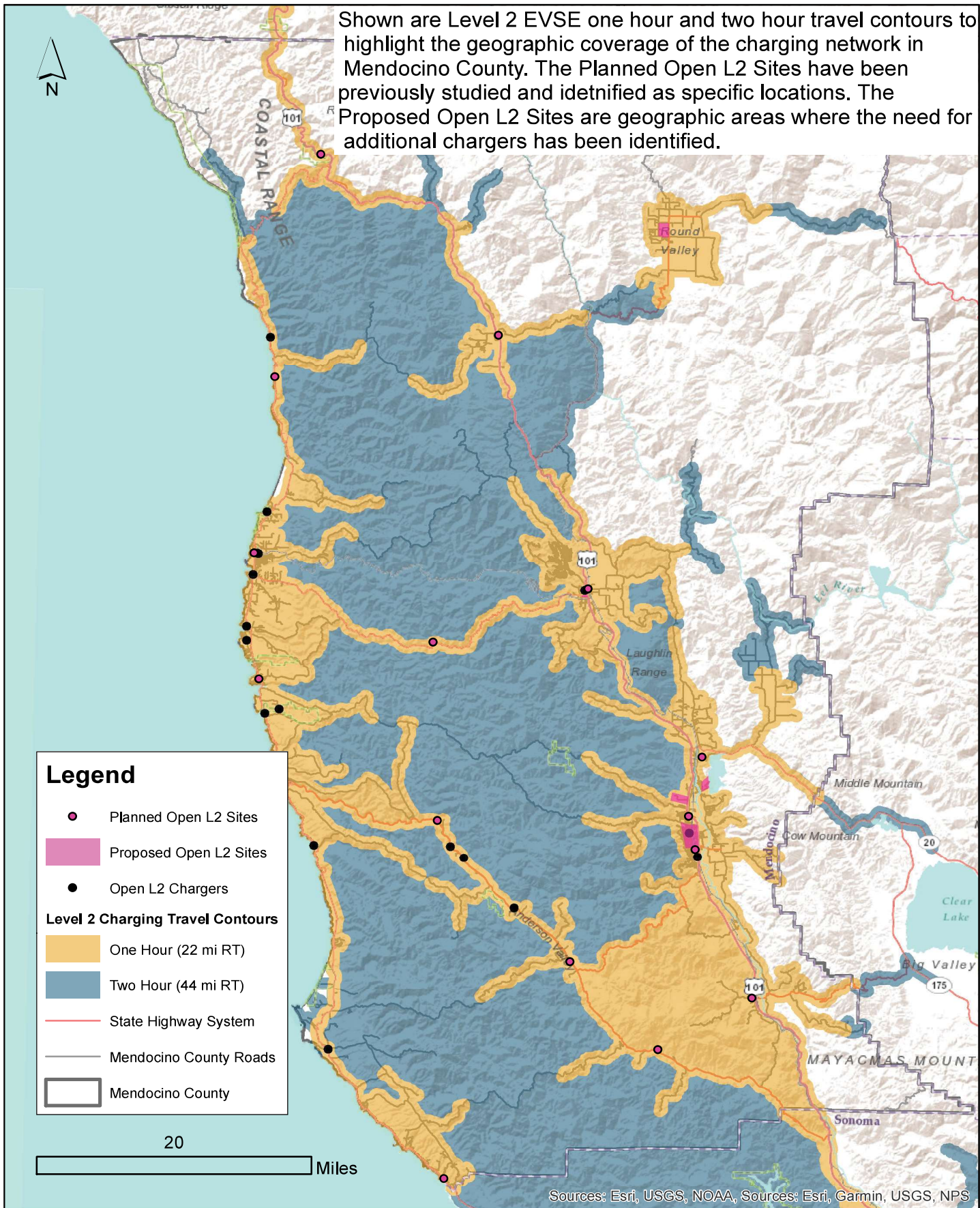

Table 9 – Core Network of Level 2 Open Access Chargers

Station Location	City	Source
Downtown	Ukiah	Current Plan
Mendocino College	Ukiah	Current Plan
Lake Mendocino	Ukiah	Current Plan
US 101 and CA 20 intersection	Willits	Current Plan
Town Center	Covelo	Current Plan
Boonville Hotel	Boonville	2013 Plan/2015 Feasibility Study
Skunk Train Depot	Fort Bragg	2013 Plan/2015 Feasibility Study
Caltrans Right of Way	Gualala	2013 Plan/2015 Feasibility Study
Hopland Fire Station	Hopland	2013 Plan/2015 Feasibility Study
Camp 20 Chamberlain Creek	Jackson State Forest	2013 Plan/2015 Feasibility Study
Fire House	Laytonville	2013 Plan/2015 Feasibility Study
The Peg House	Leggett	2013 Plan/2015 Feasibility Study
Community Center	Mendocino	2013 Plan/2015 Feasibility Study
Navarro General Store/Fire House	Navarro	2013 Plan/2015 Feasibility Study
Lake Mendocino Parking Lot	Redwood Valley	2013 Plan/2015 Feasibility Study
Corporation Yard	Ukiah	2013 Plan/2015 Feasibility Study
Crossroads Shopping Center	Ukiah	2013 Plan/2015 Feasibility Study
Abalone Street	Westport	2013 Plan/2015 Feasibility Study
Skunk Train Depot	Willits	2013 Plan/2015 Feasibility Study
Yorkville Market	Yorkville	2013 Plan/2015 Feasibility Study

Implementation Strategy

Wide scale PEV adoption in California is highly likely to continue its upward trajectory in the next five to ten years, driven by the state's ambitious goals for greenhouse gas emissions reduction, significant investments in charging infrastructure, incentives for vehicle purchase, and improvements in battery technology. However, as a rural community, Mendocino County agencies and other stakeholders will need to work together to ensure that adequate vehicle charging infrastructure is in place to serve the needs of residents and visitors. This Zero Emission Vehicle and Alternative Fuels Readiness Plan Update focuses on supporting the broader adoption of electric vehicles in Mendocino County by laying out a path for adopting supportive policies and regulations, directing resources for infrastructure to where they are most needed, and establishing an institutional framework to keep stakeholders actively engaged going forward.

More specifically, it is recommended that public agencies and other stakeholders take the following actions to implement this Plan:

1. Adopt policies and regulations to support the development of PEV infrastructure.
2. Complete the recommended Core Network and support development of the countywide charging station network.
3. Establish a Plug-In Electric Vehicle Coordinating Council.

Adopt PEV-Supportive Policies and Regulations

As previously noted, the Mendocino County Regional Transportation Plan included a policy to encourage the development of a countywide electric vehicle charging station network. General Plans provide the County and incorporated municipalities the opportunity to adopt policies to demonstrate their intention to support the further use of electric vehicles and development of the associated infrastructure. This may be accomplished through policies that address transportation, the land development process, or local agency procurement of public vehicle fleets, including light duty, heavy duty, and transit vehicles.

Jurisdictions can incorporate provisions in their respective codes to encourage the development of EV charging infrastructure, particularly through the permitting process, zoning ordinance, parking code, and building code.

6. **Permitting:** One potential barrier to implement PEV infrastructure for homeowners, business owners and charging station networks is navigating the permitting process. In 2015, as part of an effort to achieve statewide goals for PEV adoption, Governor Brown signed AB 1236, which requires counties and cities to streamline their permitting procedures for installing electric vehicle charging stations (under what is now Government Code Section 65850.7). Mendocino County and the local jurisdictions have not yet complied with AB 1236, under which agencies must adopt an ordinance requiring them to approve an application for the installation of electric vehicle charging stations unless the proposed station would have a documented adverse impact on health or safety. Streamlining the permitting process would not only support installation of PEV chargers in Mendocino County, but would also contribute toward the establishment of more uniform procedures across the state, which would be especially beneficial for charging agencies that are implementing projects in multiple jurisdictions. A sample ordinance that jurisdictions can adapt to comply with AB 1236, as well as a template for a staff report, are included in Appendix B. Additional information about permit streamlining is in Appendix C.
7. **Zoning ordinance:** Jurisdictions can provide guidance to staff and developers by including provisions in their zoning ordinances to clearly indicate their support for the installation of electric vehicle charging infrastructure. Appendix C includes a template for a zoning ordinance that would allow installation of electric

vehicle charging infrastructure in a single-family or multi-family residential garage as well as permit charging stations as an accessory use in single- or multi-family housing or in a commercial parking lot or garage.

8. **Parking requirements:** Jurisdictions can adopt code provisions to designate parking spaces as exclusively for electric vehicle use and to permit use of these spaces only while vehicles are charging (see sample code in Appendix C. Developers can also be encouraged to provide charging station infrastructure as part of projects by permitting them to count electric vehicle charging station spaces toward a project's parking requirements. In February 2019, the California Assembly introduced a bill (AB 1100) to implement this type of provision on a statewide basis.
9. **Building codes:** The California Green Building Code (CALGreen) includes provisions requiring residential and non-residential new construction projects to be designed to accommodate future electric vehicle charging infrastructure. However, many local jurisdictions have adopted provisions that include voluntary CALGreen requirements as well as the mandatory ones. Sample building code provisions are included in Appendices B and C.

Complete the Core Network and Support Additional EV Charger Development

The proposed Core Network of high priority EV charging stations will serve as a publicly available network that will offer a basic level of charging coverage throughout Mendocino County and help to minimize "range anxiety" among EV users. To accelerate the pace of implementing the network, ZAG members identified early on the need to find new revenue sources to fund the work needed to identify the specific sites for the Core Network charging station locations, to conduct the feasibility analyses, and to secure funding to purchase and install the charging infrastructure. Funding sources will potentially include not only public grants, but resources secured through the development of public/private partnerships. Inclusion in the Core Network should not be taken to mean that the public sector should take responsibility for funding, installing, and/or owning and operating these charging stations, although that will likely be the case for some stations. Implementation is an opportunistic process, and some charging stations may be implemented by area businesses. Public agencies may have opportunities to step in and secure funding as appropriate grants become available and may elect to pursue the implementation of charging stations at locations where private sector investments seem unlikely.

Due to Mendocino County's low population density, many of the Core Network locations are in relatively remote areas likely to see low demand for vehicle charging, so identifying the resources for charging stations at these low usage locations will be a challenge. In the tourist-oriented coastal communities, many businesses have elected to host charging stations to serve their customers and potentially generate new business. However, when not linked to a business, charging stations do not currently generate enough revenue to be an attractive investment. The extent to which the market will ultimately attract private investment to public charging stations is unclear, although numerous corporations are investing heavily in the development of charging networks, including automobile manufacturers and oil companies. As the use of EVs continues to grow and charging station business models evolve, the market may evolve to the point where it will address the need for stations at many locations in Mendocino County. One approach some companies are pursuing to increasing the revenue generating capabilities of charging stations is to use the stations as a platform for advertising.

Completing the proposed Core Network of high-priority EV charging stations will require significant financial resources and collaboration among various stakeholders in the County. Grant funding has been an important source of funding for EV charging stations, and that will likely be the case in the near term for the Core Network stations. Matching funds or supplemental funds needed to fully fund projects can be assembled on a case-by-case basis from entities such as local agencies, nonprofit organizations, or philanthropic organizations.

Public funding for EV charging infrastructure in California is currently available through several primary funding sources:

- **California Energy Commission (CEC):** The CEC has awarded grants that have funded many of the charging stations that currently exist or are under development in Mendocino County. This includes funding from the Alternative and Renewable Fuel and Vehicle Technology Program for DC fast chargers along 15 interregional corridors, including the US 101 corridor through Sonoma, Mendocino, Humboldt and Del Norte Counties. The CEC also funds the California Electric Vehicle Infrastructure Project (CALeVIP), which provides funding for purchase and installation of electric vehicle infrastructure at publicly accessible sites.
- **Pacific Gas and Electric (PG&E):** The California Public Utilities Commission (CPUC) has authorized several rounds of funding to PG&E and other large utilities to invest in transportation electrification projects. This includes funds for DC fast chargers, Level 2 chargers at businesses and multi-unit residential sites, and electrification of medium- and heavy-duty fleets, including transit vehicles.
- **Electrify America:** Administered by the California Air Resources Board (CARB), Electrify America is committed to spending \$800 million in California, largely for charging infrastructure. There will be four cycles of projects funded through this initiative.

Looking beyond the Core Network to include other key destinations in the County, new partnerships have been emerging to develop EV charging stations at shopping destinations, workplaces, and other locations. As indicated previously, there are currently more than 30 EV charging stations located at private businesses in Mendocino County, excluding employer-based chargers that are reserved for employees. Potential funding sources for these additional charging stations are available from numerous sources:

- **Businesses:** Businesses throughout Mendocino County have invested their own resources (often partially subsidized by government incentives or rebates) to install charging stations, largely to attract customers or encourage them to stay longer to gain additional charging time. Several larger businesses are adopting this strategy on a national scale. In recent years, companies such as Target, Walmart, and Safeway have developed partnerships with one or more charging network companies including ChargePoint, Electrify America, and Tesla. Large stores and shopping centers are often a good fit for charging stations, as customers tend to spend more time there than in smaller stores and they have large parking lots in which to site the stations.
- **Workplaces:** Large employers are often good candidates to host EV charging stations. Provision of the charging stations can often be required as part of a development agreement, but employers may also choose to voluntarily provide charging stations as an amenity to employees. Table 10 lists some of the largest employment sites in Mendocino County whose owners/operators could be approached to install charging stations.

Table 10 – Selected Large Employers in Mendocino County (100+ Employees)

Employer Name	City	Number of Employees
Little River Inn	Little River	100
Mendocino Coast District Hospital	Fort Bragg	300
Mendocino Community Health	Ukiah	130
Mendocino Forest Products	Ukiah	200
Advanced Manufacturing and Development	Willits	128
Redwood Empire Packing	Ukiah	150
Willits Hospital	Willits	283
Wal-Mart	Ukiah	250
Home Depot	Ukiah	200
Mendocino-Lake Community College	Ukiah	200

Source: D&B Hoovers

- Tesla Destination Charging Network:** Many businesses in Mendocino County have partnered with Tesla as part of the company’s Destination Charging Network, through which Level 2 chargers are installed at private businesses such as hotels and wineries. Tesla typically provides the charger and sometimes installation for free. In some cases, they have also included non-Tesla chargers as part of the arrangement, expanding the charging network for owners of PEVs other than Teslas. Many of these chargers are only available for use by customers of the hosts, but in some cases non-customers may use the chargers for a fee.
- Peer-to-Peer Networks:** While not a funding source, peer-to-peer networks may provide an effective means of expanding the number of vehicle-charging stations, much in the way Airbnb has done with accommodations. While still very early in development, several companies have formed to attempt to develop this model which, if successful, would transform existing private facilities into ones accessible by the public. An example of a peer-to-peer network is EV Match (<http://www.evmatch.com>), which was initiated in southern California.

Stations funded through some of these sources are available to the public to varying degrees. For example, Tesla chargers are currently only usable by Tesla vehicles due to their proprietary technology. Other charging stations are limited to use by customers of the host business. More limited are stations only available to employees at a work site or to vehicle fleets. However, these are all critical elements of the County’s PEV charging network as they provide users with opportunities to charge their vehicles in conjunction with various trips they make throughout the week work, shopping, recreation, etc., to supplement their home charging.

Develop a Plug-In Electric Vehicle Coordinating Council (PEVCC)

Partnerships will be a critical ingredient in the development of implementing the recommended priority PEV charging station network in Mendocino County, to expand the implementation of charging infrastructure more generally, and to track ongoing developments in EV infrastructure planning, technology development, and financing innovations. There are numerous public and private sector stakeholders with key roles to play in these efforts, including for local, regional, and state agencies; utilities; large employers; charging networks; property owners; and others.

The *Northwest California Alternative Fuels Readiness Plan* recommended the development of a Clean Cities Coalition to bring together stakeholders to support the broader adoption of alternative fuel vehicles, including electric vehicles. Local Clean Cities Coalitions, which operate under the umbrella of the U.S. Department of

Energy's Clean Cities Program, have been established in nearly 100 communities across the U.S. to coordinate the efforts of public and private sector partners in supporting alternative fuels development.

Among the stakeholders identified in the Plan as participants in the Coalition was a representative of a Plug-in Electric Vehicle Coordinating Council (PEVCC). PEVCCs have been used in other parts of California to bring together stakeholders to collaborate on promoting/implementing electric vehicles. The California Energy Commission has acknowledged the importance of stakeholder collaboration in the electric vehicle planning process, as consultation with a PEVCC was a requirement to receive readiness planning funding.

Maintaining an ongoing PEVCC can be particularly challenging for rural communities given their limited staff resources. To best serve the needs of jurisdictions in Mendocino County, a less resource-intensive alternative could be joining with other rural communities in northern California, which would enable local stakeholders to draw on a broader base of expertise. One option for establishing such a forum is to explore expansion of the North Coast PEVCC – which currently focuses on EV development in the Counties of Humboldt, Del Norte, and Trinity – to include Mendocino County. Alternatively, a coordinating council could potentially be established across a larger area in northern California under the umbrella of the existing North State Super Region. The 16-County Super Region – whose members include Mendocino County as well as the three counties represented in the North Coast PEVCC – was established in 2010 to coordinate and bring attention to regional transportation issues in the area.

Working as part of a larger regional entity would enable Mendocino County agencies to draw on the experience of agencies in that area and to share the cost of providing staff and other resources to support the PEVCC. Given the large area encompassed by both the North Coast area and the Super Region, the PEVCC would need to meet largely online or by phone or video-conference, with in-person meetings perhaps once or twice a year. Between meetings, communication and resource sharing can occur via a web-based forum for members, which will enable local stakeholders to draw on significant expertise from communities facing similar issues.

Potential Functions of a PEVCC

A coordinating council would be able to support the implementation of electric vehicle charging infrastructure and the broader adoption of electric vehicles in Mendocino County in numerous ways.

1. **Best practices:** The models for implementing electric vehicle charging infrastructure are continuing to evolve. Each jurisdiction has unique processes for approving electric vehicle infrastructure and there are different arrangements regarding which entity owns the equipment, assumes maintenance responsibility, sets user fees (if any), etc. As electric vehicle adoption continues its rapid growth, jurisdictions are continually learning what approaches have been successful and where adjustments are needed. A coordinating council would provide a forum for jurisdictions to learn from one another and circulate examples of best practices that have been effective in other regions or locally.
2. **Funding opportunities:** The landscape of electric vehicle development is rapidly evolving. The coordinating council would provide a valuable mechanism for sharing information about available funding sources.
3. **Advocacy:** An ongoing dialogue among local stakeholders would help identify issues that could potentially be addressed at the County, state, or federal level. The coordinating council would enable public and private sector entities to develop recommendations that they could collectively support and work with their legislators to generate support to address the electric vehicle infrastructure needs of rural communities.
4. **Coordination:** A PEVCC would enable agencies to more closely monitor the evolving coverage of the electric vehicle charger network by tracking the development of new facilities in other jurisdictions throughout the county and in neighboring counties. Maintaining this regional perspective could also help identify opportunities for participants to develop joint funding applications.

5. **Facilitate dialogue between public and private sector:** By including both public and private sector stakeholders, the coordinating council could help better identify obstacles and challenges to electric vehicle infrastructure development and explore the potential for public/private partnerships.
6. **Education and marketing:** Participants representing business or economic development interests would be well-positioned to conduct outreach to large employers and commercial developments about the potential benefits of hosting electric vehicle charging stations for customers and employees. Outreach could also be conducted to the owners/managers of vehicle fleets to consider conversion of fleets to electric vehicles.
7. **Information sharing:** An email discussion group, list-serve or similar format, would offer a forum for ongoing dialogue among stakeholders across the region. The online format enables participants to post questions and respond. Such lists are most effective when they have many participants as they can draw on their collective expertise.

Participants in a PEVCC

There are a significant number of stakeholders in Mendocino County that have a role to play in the development of EV charging infrastructure. As a regional entity with relationships to agencies and organizations throughout the County and in other jurisdictions, MCOG would be well positioned to assume a coordinating role for a PEVCC. Potential PEVCC participants could include the following members.

Mendocino Council of Governments

Jurisdictions: County of Mendocino, cities of Ukiah, Willits, Fort Bragg, and Point Arena

Mendocino County Air Quality Management District

Utilities: Sonoma Clean Power, PG&E, Ukiah Public Utilities

Native American Tribal Governments

Mendocino Land Trust

Electric vehicle charging networks

Business leaders and associations

Tourism groups

Caltrans District 1

Municipal Advisory Councils in county unincorporated areas

Mendocino County Office of Education

Study Participants and References

Study Participants

Principal in Charge	Steve Weinberger, PE, PTOE,
Transportation Planner	Barry Bergman
Associate Planner	Nick Bleich, AICP, EIT
Graphics	Katia Wolfe
Editing/Formatting	Katia Wolfe
Quality Control	Dalene J. Whitlock, PE, PTOE

References

- Alternative Fuels Charging Stations, Alternative Fuels Data Center, U.S. Department of Energy, <https://afdc.energy.gov/stations/#/find/nearest>
- California Energy Commission, Requests for Proposals, Contracts, and Solicitations, <https://www.energy.ca.gov/contracts/>
- California Manual on Uniform Traffic Control Devices for Streets and Highways*, California Department of Transportation, 2014
- Clean Cities Coalition Network, <https://cleancities.energy.gov/>
- Driving to Net Zero*, County of Santa Clara, <https://www.sccgov.org/sites/dnz/Pages/home.aspx>
- Electric Vehicle Charging Station Permitting Guidebook*, Governor's Office of Business and Economic Development (GO-Biz), 2019 (forthcoming).
- Plug-In Electric Vehicle Handbook for Fleet Managers*, U.S. Department of Energy, https://afdc.energy.gov/files/pdfs/pev_handbook.pdf
- Plug-In Electric Vehicle Handbook for Public Charging Station Hosts*, U.S. Department of Energy, <https://afdc.energy.gov/files/pdfs/51227.pdf>
- Plug-In Electric Vehicle Handbook for Workplace Charging Hosts*, U.S. Department of Energy, https://afdc.energy.gov/files/u/publication/pev_workplace_charging_hosts.pdf
- Plug-In Electric Vehicle Resource Center, https://www.driveclean.ca.gov/pev/CA_Plug-In_Electric_Vehicle_Collaborative.php
- Zero Emission Vehicles, Governor's Office of Planning and Research, <http://www.opr.ca.gov/planning/transportation/zev.html>

Appendix A

Electric Vehicle Charging Station Accessibility Requirements

DRAFT



This page intentionally left blank

Summary of 2016 California Building Code Changes for Electric Vehicle Charging Station (EVCS) Accessibility

The California Building Standards Commission adopted accessibility standards for electric vehicle charging stations (EVCS) as part of the 2016 code adoption cycle. These changes in the 2016 California Building Code (California Code of Regulations, Title 24) become effective January 1, 2017.

This fact sheet provides a brief overview of the requirements. For full scoping and technical requirements of the building standards for EVCS, please refer to the full text of the California Building Code regulations at <http://www.bsc.ca.gov/Codes.aspx> (Part 2, Volume 1). The building code amendments include provisions in:

- Chapter 2 – Definitions
- Chapter 11B – Accessibility to Public Buildings, Public Accommodations, Commercial Buildings and Public Housing

Part 2 – California Building Code – Chapter 2 - Definitions

DEFINITION	NOTES
Drive-up electric vehicle charging station	New definition for electric vehicle charging station that functions similar to a gasoline filling island.
Electric Vehicle (EV)	New definition for vehicles powered by electricity that are considered electric vehicles for the purpose of Chapter 11B.
Electric Vehicle (EV) charger	New definition for equipment used to charge electric vehicles.
Electric Vehicle charging space (EV space)	New definition for the vehicle space intended for charging electric vehicles.
Electric Vehicle charging station (EVCS)	New definition for one or more EV charging spaces served by an electric vehicle charger.
Electric vehicle (EV) connector	New definition for the device that connects to the electric vehicle for the purpose of charging. Device is part of the electric vehicle coupler.

Part 2 – California Building Code – Chapter 11B

SECTION	TITLE	NOTES
11B-228.3	Electric vehicle charging stations	Provides scoping for electric vehicle charging stations installed in new and existing facilities with Table 11B-228.3.2.1 to determine the number of accessible EVCS required. Provides reference to 11B-812 for technical requirements for EVCS.
11B-812	Electric vehicle charging stations	Provides new section with technical provisions for EVCS.
11B-812.1	General.	General requirements for the dimensions and marking of EV charging spaces and access aisles.
11B-812.2	Operable parts.	Technical requirements for operable parts of the EVCS.
11B-812.3	Floor or ground surfaces.	Technical requirements for floor and ground surfaces of the EVCS.
11B-812.4	Vertical clearance.	Provisions for vertical clearance requirements at EVCS.
11B-812.5	Accessible routes	Provides requirements for accessible routes to electric vehicle chargers and to a building entrance.
11B-812.6	Vehicle spaces.	Provides dimensions for length of van accessible, standard accessible, ambulatory and drive-up EVCS.
11B-812.7	Access aisle.	Provides requirements for the access aisle adjacent to the electric vehicle charging space.
11B-812.8	Identification signs.	Provides general scoping for the technical sections for identification signs for accessible EVCS.
11B-812.9	Surface marking.	Provides requirements for the surface markings at EVCS.
11B-812.10	Electric vehicle chargers.	Technical requirements for electric vehicle chargers, which includes the requirements for operable parts, point-of-sale devices and location of the chargers in relation to the EV space.

Electric Vehicle Charging Stations, Accessibility: FAQs

INTRODUCTION:

The Division of the State Architect's *Electric Vehicle Charging Stations, Accessibility: FAQs* is part of DSA's ongoing effort to promote consistency in the design and construction of projects.

This document addresses five categories of frequently asked questions about new California Building Code accessibility requirements for electric vehicle charging stations:

- General Questions,
- Accessible Route & Path of Travel Questions,
- Scoping Questions,
- Technical Questions, and
- Miscellaneous Questions

The questions are presented as received by DSA or as composites of related questions.

It is important to note that the remarks in this document are intended to be informative but they are not a substitute for the requirements of the California Building Code. Also, despite the informative nature of this document, it is the appropriate jurisdictional code official who possesses the exclusive authority to enforce and interpret the requirements of the California Building Code. This document provides informal assistance regarding California accessibility requirements only for DSA's code-enforcement jurisdiction. The information contained in this document is not binding on the Division of the State Architect and is not intended or designed to give any legal advice on compliance with federal, state, or local laws and regulations. It should be noted that laws, regulations, and standards are subject to revisions, additions, or deletions, at any time.

ABBREVIATIONS:

The following abbreviations are used in this document:

ADA:	Americans with Disabilities Act	EV:	Electric Vehicle
CBC:	California Building Code	EVCS:	EV Charging Station
DCFC:	DC Fast Charge	EVSE:	EV Service Equipment
DSA:	Division of the State Architect		

Note: This FAQ addresses EVCS installed at *public buildings, public accommodations, commercial facilities and public housing*. EVCS installed at *privately-owned multifamily housing facilities* may also have requirements for accessible EVCS dependent on use; please consult with the Department of Housing and Community Development for requirements.

Electric Vehicle Charging Stations, Accessibility: FAQs

GENERAL QUESTIONS:

At what types of property/sites must the ADA requirements be met?

RESPONSE: EVCS installed at public buildings, public accommodations, commercial facilities and public housing are required to comply with the accessibility requirements in CBC Chapter 11B. Also, under the American with Disabilities Act there is a general obligation to provide accessible EVCS; however, specific requirements for EVCS have not been adopted in the ADA Standards for Accessible Design.

What types of exemptions or exceptions exist?

RESPONSE: EVCS installed at public buildings, public accommodations, commercial facilities and public housing are required to comply with the accessibility requirements in CBC Chapter 11B. Compliance with these provisions is not required where EVCS are not available to the general public and intended for use by a designated vehicle or driver (see CBC Section 11B-228.3.2 Exception 1).

Does the state architect intend to provide further statewide guidance or will implementation remain a more regional/local decision?

RESPONSE: The Division of the State Architect will continue its outreach efforts to inform the public about the new accessibility requirements for EVCS. However, the requirements in the CBC are enforced by various code enforcement officials, including city and county building departments, within their respective jurisdictions.

Are multi-unit dwellings of any kind covered under the requirements? Our thinking stemmed from the fact that it covers public housing, but how is public housing defined? For example, is section 8 housing applicable? Are all condos and apartments applicable if they are providing charging for any of their residents and not just a specific resident?

RESPONSE: Privately owned multi-family dwellings are not subject to the new CBC Chapter 11B accessibility requirements for EVCS. The new requirements do apply at public housing facilities which are defined below. CBC Chapter 11B accessibility requirements do not apply to Section 8 housing credit recipients – the Section 8 program is a housing voucher program, not a public housing program.

PUBLIC HOUSING. Housing facilities owned, operated, or constructed by, for or on behalf of a public entity including but not limited to the following:

1. Publically owned and/or operated one- or two-family dwelling units or congregate residences;
2. Publically owned and/or operated buildings or complexes with three or more residential dwelling units;
3. Reserved.

Electric Vehicle Charging Stations, Accessibility: FAQs

- 4. Publically owned and/or operated homeless shelters, group homes and similar social service establishments;*
- 5. Publically owned and/or operated transient lodging, such as hotels, motels, hostels and other facilities providing accommodations of a short term nature of not more than 30 days duration;*
- 6. Housing at a place of education owned or operated by a public entity, such as housing on or serving a public school, public college or public university campus;*
- 7. Privately owned housing made available for public use as housing.*

Electric Vehicle Charging Stations, Accessibility: FAQs

ACCESSIBLE ROUTE & PATH OF TRAVEL QUESTIONS:

Are the elements of path of travel and accessible routes substantively the same (such as slope, vertical clearance, width of path of travel, etc.)?

RESPONSE: The terms ACCESSIBLE ROUTE and PATH OF TRAVEL are distinct but related.

Accessible route is a fundamental term used to describe, “A continuous unobstructed path connecting accessible elements and spaces of an accessible site, building or facility that can be negotiated by a person with a disability using a wheelchair, and that is also safe for and usable by persons with other disabilities...” In short, we can think of it as the ground surface which allows travel by wheelchair. The technical requirements are in CBC Chapter 11B Divisions 3 (Building Blocks) and 4 (Accessible Route). EVCS required by CBC Chapter 11B to be accessible must have an accessible route to the facility entrance (see CBC Section 11B-812.5.1) and an accessible route from the vehicle space to the EVSE (see CBC Section 11B-812.5.2). No exceptions are provided but you can use existing accessible routes to help satisfy these requirements.

Path of travel is a term exclusively used in CBC Chapter 11B within the context of alterations to existing sites (see Section 11B-202.4, including Exception 10). For EVCS projects it only applies where EVCS are installed at existing facilities where vehicle fueling, recharging, parking or storage is a primary function. These types of facilities include gas stations, stand-alone parking lots and stand-alone parking structures (see Section 11B-202.4 Exception 10). When an accessible path of travel is required, an accessible path of travel to the specific area of alteration shall be provided; this path of travel, by definition in Chapter 2 of the CBC, includes a primary entrance to the building or facility, toilet and bathing facilities serving the area of alteration, drinking fountains serving the area of alteration, public telephones serving the area of alteration, and signs as well as accessible routes which connect the area of alteration with site arrival points such as sidewalks, streets, and accessible parking (see CBC Section 11B-202.4). These listed elements – primary entrance, toilet and bathing facilities, drinking fountains, public telephones, signs and site arrival points as well as accessible routes connecting all of them – are sometimes called “path of travel elements.” These elements are required to comply with the current code requirements or be brought into compliance when an alteration occurs. Compliance is required to the maximum extent feasible without exceeding 20 percent of the cost of the work directly associated with the installation of EVCS (see Section 11B-202.4 Exception 10).

When do path of travel and/or accessible routes apply? ...new construction? ...alterations to a parking area? ...alterations to a building associated with parking, such as expansion or remodel?

RESPONSE: In each case EVCS required to be accessible must have an accessible route to the facility entrance (see CBC Section 11B-812.5.1) and an accessible route from the vehicle space to the EVSE (see CBC Section 11B-812.5.2).

Electric Vehicle Charging Stations, Accessibility: FAQs

In the new construction of a new facility, all accessible rooms and spaces are required to be connected by an accessible route and all toilet facilities, drinking fountains, public telephones and signs are subject to accessibility requirements. These fundamental requirements provide accessibility in excess of that required for alterations to existing facilities so the regulations associated with path of travel requirements are not applicable to new facilities.

In general, when alterations are made to existing buildings or facilities, an accessible path of travel to the specific area of alteration shall be provided; this path of travel includes a primary entrance to the building or facility, toilet and bathing facilities serving the area of alteration, drinking fountains serving the area of alteration, public telephones serving the area of alteration, and signs as well as accessible routes which connect the area of alteration with site arrival points such as sidewalks, streets, and accessible parking (see CBC Section 11B-202.4). In general, these listed elements, if provided on the site, are required to comply with the current code requirements or be brought into compliance when an alteration occurs. In the context of EVCS, this scheme will apply when EVCS are installed at existing facilities where vehicle fueling, recharging, parking or storage is a primary function. These types of facilities include gas stations, stand-alone parking lots and stand-alone parking structures. Compliance is required to the maximum extent feasible without exceeding 20 percent of the cost of the work directly associated with the installation of EVCS (see Section 11B-202.4 Exception 10).

Where EVCS are installed at facilities where vehicle fueling, recharging, parking or storage is NOT a primary function, compliance with Section 11B-202.4 is NOT required (see Section 11B-202.4 Exception 10). These types of facilities include shopping centers, individual stores and office buildings. While parking is frequently provided at these types of facilities, parking is not the primary function – shopping or conducting business is the primary function at these facilities.

There is some confusion about whether the “accessible path” that is required means there must be an accessible path from the EVSE (charger) to the facility/building at which the station is installed, or whether the accessible path is just from the parking spot to the EVSE (charger). If the prior is enforced, it could increase the costs of installing EVSE in some instances. What is the correct interpretation of “accessible path”?

RESPONSE: The term used in the CBC is “accessible route.” EVCS required by CBC Chapter 11B to be accessible must have both, an accessible route to the facility entrance (see CBC Section 11B-812.5.1) and an accessible route from the vehicle space to the EVSE (see CBC Section 11B-812.5.2).

What occupancies are or are not subject to path of travel and/or accessible routes? ...buildings subject to California Building Code (CBC) Chapter 11B? ...multi-family buildings subject to CBC Chapter 11A? ...others?

RESPONSE: Buildings and facilities required to comply with Chapter 11B, including public housing facilities, are required to comply with the CBC Chapter 11B accessibility provisions for EVCS. This includes the accessible route requirements for installation of

Electric Vehicle Charging Stations, Accessibility: FAQs

EVCS. In addition, an accessible path of travel is required where EVCS are installed at existing facilities where vehicle fueling, recharging, parking or storage is a primary function. These types of facilities include gas stations, stand-alone parking lots and stand-alone parking structures. Compliance with path of travel requirements is required to the maximum extent feasible without exceeding 20 percent of the cost of the work directly associated with the installation of EVCS (see Section 11B-202.4 Exception 10). See note on page 1 of this FAQ for privately-owned multifamily housing facilities subject to CBC Chapter 11A, and under the regulatory authority of the Department of Housing and Community Development.

If a property owner hits the 20% cost cap on path of travel improvements when installing charging stations, are there any other accessibility site retrofits that would still be required?

RESPONSE: EVCS required to be accessible by CBC Chapter 11B must have both, an accessible route to the facility entrance (see CBC Section 11B-812.5.1) and an accessible route from the vehicle space to the EVSE (see CBC Section 11B-812.5.2). No exceptions are provided but you can use existing accessible routes to help satisfy these requirements. These requirements are separate from, and are not limited by the 20% cost cap on path of travel improvements.

When a property owner hits the 20% cost limitation on path of travel improvements, the jurisdictional entity cannot require further improvements to the path of travel to occur. The property owner should be advised, however, that for older facilities that pre-date the ADA, barrier removal is required by the ADA. Barrier removal, however, will not be enforced by the local jurisdictional entity.

Electric Vehicle Charging Stations, Accessibility: FAQs

SCOPING QUESTIONS:

Can a single EV charger service two EV Accessible spots or does each spot have to have its own charger?

RESPONSE: A single multiport EV charger that can simultaneously charge two vehicles can be used to serve two EV spaces required to be accessible. An EV charger that can only charge one vehicle at a time cannot be used to serve two EV spaces required to be accessible. (see CBC Chapter 2 definition of “Electric Vehicle Charging Station”)

How can we address locations that do not have excess parking spaces and currently, cannot pass through plan check because the code says it's now a “charging space” not a “parking space”? With the current requirements, you need more Van Accessible and ADA reserved parking spaces than required under code with the combination of EV charging and standard spaces. It puts an impossible burden on small parking lots in Irvine and San Diego which are strictly enforcing the interpretation of charging spaces.

RESPONSE: All work is required to comply with the applicable codes, standards and ordinances. Parking ordinances are typically adopted within each city and county in California. Consistent with the state's policies on electric vehicles, DSA encourages city and county officials to recognize the necessary impact of EVCS and adopt responsive ordinances consistent with the local needs.

Can you upgrade/expand an existing location without adhering to ADA standards?

RESPONSE: No. To the extent that EVCS are a public accommodation or commercial facility they are covered by the federal law of the Americans with Disabilities Act. The new accessibility requirements in the CBC are intended to provide full compliance with the requirements of the ADA. Compliance will help property owners meet their legal obligations under the ADA and avoid costly legal actions.

Many properties do NOT have enough electricity available to support significant charging installations, so for now, utilities and others are doing “make ready” spaces (upgrading the supporting infrastructure in a parking space for future use without adding the actual charger). How would make ready spaces comply with the ADA standards? Additionally, consider a site with 10 make ready spaces. Would the standards apply differently if that site has no chargers presently installed versus having one active charger installed?

RESPONSE: The CBC definition for Electric Vehicle Charging Station (EVCS) describes “One or more electric vehicle charging spaces served by an electric vehicle charger or other charging equipment.” Where a vehicle space is not provided with a charger it is not, by definition, an EVCS. CBC Chapter 11B accessibility provisions only apply to vehicle spaces with a charger.

If the entire project consists of 10 vehicle spaces with the infrastructure installed, but

Electric Vehicle Charging Stations, Accessibility: FAQs

without chargers, then CBC Chapter 11B accessibility provisions do not apply.

If the entire project consists of 9 vehicle spaces with the infrastructure installed, but without chargers, and one other vehicle space is provided with a charger, then the CBC Chapter 11B accessibility provisions apply only to the vehicle space with a charger.

It would be prudent for a designer to take into consideration the space requirements necessary for accessible EVCS based on the total projected number of EVCS planned for the site, in addition to future accessible route requirements, so that the future installation of EVCS can be accommodated, but accessibility provisions are not required unless electric vehicle charging equipment is installed.

For a new public building, if EV charging equipment is not installed at this time, what is the extent of the infrastructure that an installer is required to show for plan check review?

RESPONSE: Plans and specifications must accurately describe the full extent of the work to be performed. Some enforcement jurisdictions (primarily city- and county building departments) may have additional requirements.

Looking at Cal Green 5.106.5.3, we must provide the conduits and panel capacity for future installation for the required number of spaces (2 in this case). However, it is only when the equipment is to be installed that we need to refer to CBC and CEC. Section 11B-228.3.1 also reiterates this. Therefore, we would show the location of the conduit stub outs adjacent to 2 current parking spaces and would show space on the electric panel for the future equipment – and that is all. At this time, we do not need to show the requirements for EV accessibility when equipment is installed per Chapter 11B. Is my interpretation correct?

RESPONSE: CBC Chapter 11B accessibility provisions for EVCS apply when a project consists of one or more electric vehicle charging spaces served by an electric vehicle charger or other charging equipment. Where the project does not provide charging equipment the code does not require the provision of accessible routes or other vehicle space accessibility requirements. However, it is good practice to notify the owner or owner's representative of any additional code requirements that will be triggered by the later installation of charging equipment. The owner can use this information to determine the sequence and extent of work to be included in each phase of the project.

All work is required to comply with the applicable codes and standards. Plans and specifications must accurately describe the full extent of the work to be performed. Some enforcement jurisdictions (primarily city- and county building departments) may have additional requirements.

We are also being asked to show the future space for the 1 Van accessible EV space that would be required in the future, if the equipment was installed. And due to the requirement for the access aisle beside this space, in the future it would be converted to an access aisle resulting in the loss of one parking space. As this project is right at the required number of parking spaces per zoning, it is not acceptable to the zoning reviewer to sign off on a plan that shows a "future

Electric Vehicle Charging Stations, Accessibility: FAQs

access aisle for future EV van accessible charging space,” as they are approving the loss of a parking space, even though this would not happen until a future condition, upon which I assume there would be some review process for installation of EV charging equipment. What is the appropriate path forward in this situation?

RESPONSE: All work is required to comply with the applicable codes, standards and ordinances. Parking ordinances are typically adopted within each city and county in California. Consistent with the state’s policies on electric vehicles, DSA encourages city and county officials to recognize the necessary impact of EVCS and adopt responsive ordinances consistent with the local needs.

On existing locations when we add an EV station as van accessible how do we address taking two spaces from the facility (losing a space) and then not having the mandatory spaces remaining for the facility?

RESPONSE: All work is required to comply with the applicable codes, standards and ordinances. Parking ordinances are typically adopted within each city and county in California. Consistent with the state’s policies on electric vehicles, DSA encourages city and county officials to recognize the necessary impact of EVCS and adopt responsive ordinances consistent with the local needs.

I fully support ADA requirements and the DGS' efforts. We are reconstructing a 325 space parking lot. 8% will be EVSE ready. 32 EVSE will be installed initially. Including EVSE required ADA spaces, new plan results in 322 spaces. Parking facility no longer complies with minimum parking requirements for facilities. Any suggestions for resolving this conflict for reworking of existing sites subject to CALGreen?

RESPONSE: Parking ordinances are typically adopted within each city and county in California and enforced by local planning department personnel. You could consider requesting a variance from full compliance with the parking requirements substantiated by the benefits of electrical vehicle use which relies on installed infrastructure.

There does not seem to be a distinction between different EVCS standards (Level 1, Level 2, DC CHAdEMO, DC CCS, and Tesla). Does the schedule defined in Table 11B-228.3.2.1 make a distinction between the different types of EVSE standards or are that all considered to equivalently be an EVCS?

RESPONSE: The CBC Chapter 11B accessibility requirements for EVCS do not distinguish between the different EVCS standards like those listed. However, building officials may view different types of service as separate facilities. Where different types of EVCS service are provided at a location, the code enforcement official must determine the applicability of Table 11B-228.3.2.1.

When developing the CBC Chapter 11B accessibility provisions for EVCS, it was DSA’s intent to provide a reasonable portion of all EVCS facilities as accessible to and usable

Electric Vehicle Charging Stations, Accessibility: FAQs

by persons with disabilities.

We often see projects of gas station replacing old fuel dispensers with access compliance fuel dispensers (reach range, operable parts, point-of-sale). According to Section 11B-202.4, Exception 10, these projects would be required to comply with accessibility for primary accessible path to inside the convenient store at the gas station, public restrooms, drinking fountains, public telephones, and signs (with 20-percent limit of adjusted construction cost). Is my understanding correct regarding the replacement of old/addition of new fuel dispensers?

RESPONSE: Exception 10 to Section 11B-202.4 is only applicable to the installation of EVCS – the exception does not apply to gasoline filling equipment. However, Section 11B-202.4 Exception 8 may be used when replacing gasoline fuel dispensers.

Is DSA aware of existing precedents (potentially from past experience with non-EV accessible parking) to address the factors that would be considered to determine whether compliance with EV accessibility rules would be technically infeasible?

RESPONSE: A request for technical infeasibility is made to and determined by the local jurisdiction. A request for technical infeasibility is site-specific; therefore, there are no general factors that could be considered to determine whether compliance with EVCS regulations is technically infeasible.

Electric Vehicle Charging Stations, Accessibility: FAQs

TECHNICAL QUESTIONS:

For small parking lots, is there any variance on being able to share EV charging with the existing accessible parking spaces?

RESPONSE: The accessibility provisions in CBC Chapter 11B do not permit a required accessible EVCS to be installed in a required accessible parking space. Section 11B-208.1 notes, "For the purposes of this section, electric vehicle charging stations are not parking spaces..."

Can you put an EV charger in an existing accessible parking space instead of doing costly upgrades?

RESPONSE: The accessibility provisions in CBC Chapter 11B do not permit a required accessible EVCS to be installed in a required accessible parking space. Section 11B-208.1 notes, "For the purposes of this section, electric vehicle charging stations are not parking spaces..."

Currently, the DCFC time limit is 30 minutes maximum. New larger battery capacity will take longer to get 80% charge – i.e. Chevy Bolt EV, Tesla Model 3, 2018 Nissan LEAF, etc. Can we reconsider the time limit?

RESPONSE: The 30 minute time limit applies to drive-up EVCS of any type. This design option allows brief charging and queuing for charging service, and does not consider that batteries will be charged to full capacity. Where DCFC or any other type of charging is intended for use longer than 30 minutes, EVCS may be provided in regular parking-style vehicle spaces.

CAL Green requires x number of EVSE per xxx number of spaces - each on its own 40 amp circuit. Some dual EVSE are on a single 40 amp circuit and split the 40 amp. Does this mean that half of those plugs don't comply with the required number?

RESPONSE: The California Green Code appears to require service panels, sub-panels, and raceway of sufficient capacity to accommodate 40 amp circuits rather than mandating one 40 amp circuit for each EVCS in residential and nonresidential locations. For additional information you may contact the Department of Housing and Community Development for infrastructure requirements at residential locations or the Building Standards Commission for infrastructure requirements at nonresidential locations.

Can you provide recommended signage for ADA accessible spaces?

RESPONSE: Required identification signs for accessible EVCS vehicle spaces are indicated in CBC Chapter 11B Section 11B-812.8 and required vehicle space surface markings are indicated in Section 11B-812.9. Other courtesy messages may be provided

Electric Vehicle Charging Stations, Accessibility: FAQs

but are not required by CBC Chapter 11B.

For projects within the public rights-of-way, the California Department of Transportation (Caltrans) has several signs for EV charging in its California Manual on Uniform Traffic Control Devices. For the appropriate use of these signs you may contact Caltrans.

What are the auditory/braille requirements for EVCS units with a touch screen?

RESPONSE: Accessibility requirements for all point-of-sale devices have been a part of the CBC for many years and allow people with vision impairments to conduct automated transactions in a secure manner. These requirements apply to point-of-sale devices in public buildings, public accommodations commercial buildings and public housing, including restaurants, stores, banks, theaters and DVD rental kiosks – just about anywhere the public conducts automated transactions.

The new CBC accessibility requirements for EVCS specifically identify that each EVCS, whether or not accessible, provided with a point-of-sale device must provide a tactilely discernable numerical keypad, like a push-button telephone keypad or some other technology such as RFID, biometric fingerprint or other mechanism that allows access and privacy (see CBC Section 11B-707.9.1).

Where EVCS are provided with a touch screen but without point-of-sale devices, neither the CBC nor the ADA Standards for Accessible Design provide explicit requirements for the touch screen accessibility. However, Title III of the ADA prohibits discrimination against individuals “...on the basis of disability in the full and equal enjoyment of the goods, services, facilities, privileges, advantages or accommodations of any place of public accommodation...” (see 42 U.S.C. § 12182(a)) Past court cases have indicated that accessibility must be provided at places of public accommodation and governmental programs and services, even in the absence of explicit requirements. Accordingly, DSA advises that designers incorporate touch screen accessibility into their projects.

Electric Vehicle Charging Stations, Accessibility: FAQs

MISCELLANEOUS QUESTIONS:

Can a disabled non-EV driver park in an ADA EVSE spot?

RESPONSE: The California Vehicle Code prohibits parking a vehicle in an EVCS. Vehicles left in EVCS spaces must be connected for charging purposes. DSA understands this applies to accessible EVCS too.

Will CALGreen be amended to require that some parking spaces are designed so that they can comply with Chapter 11B requirements when converted to EV charging spaces (i.e. slope, vertical clearance, path of travel)?

RESPONSE: DSA is not aware of any efforts to amend the California Green Code in this manner. While the California Green Code nonresidential mandatory measures require projects to identify an EV space, provide an electrical raceway to the service panel, and provide adequate capacity at the service panel for future EVCS; good design practice would be to incorporate appropriate ground surfaces and routes to facilitate the later installation of usable accessible EVCS. Plans and specifications must accurately describe the full extent of the work to be performed. Some enforcement jurisdictions (primarily city- and county building departments) may have additional requirements.

What accessibility requirements apply to EV charger installation outside of California?

RESPONSE: To the extent that EVCS are a public accommodation or commercial facility they are covered by the federal law of the Americans with Disabilities Act. Specific technical requirements for EVCS are not specified in the 2010 ADA Standards for Accessible Design. DSA is not familiar with state and municipal accessibility requirements for EVCS outside of California.

Has there been consideration for electric vehicles being parked in valet mode that could share EVSE and meet the equivalent EVSE option? This could reduce the cost of construction and major electrical upgrades.

RESPONSE: Electric vehicles may be parked by a valet just as any other car. CBC Chapter 11B does not contain specific accessibility provisions for situations where the valet service provides EV charging in addition to parking service. Absent specific requirements, this situation would require the building official to determine the extent of applicable accessibility requirements on a case-by-case basis. DSA encourages designers to consult with jurisdictional building officials (primarily city- and county building departments) whenever there is a question of code interpretation or application.

It appears that the accessibility standards may result in lots of chargers in ADA spaces not being used or “stranded assets.” Was this issue addressed in development of the standards?

Electric Vehicle Charging Stations, Accessibility: FAQs

RESPONSE: This issue was discussed extensively during development of the CBC Chapter 11B accessibility provisions for EVCS. The requirements were developed to provide full compliance with federal and California accessibility law without placing an excessive burden on the property owners.

Vehicle spaces which display the International Symbol of Accessibility (ISA), sometimes referred to as the wheelchair symbol, are generally understood to be reserved for the exclusive use of a disabled person displaying special license plates or a distinguishing placard. It is important to remember that a disability placard or special license plate with an ISA can be issued to a driver or passenger for a disability that does not necessitate the use of a wheelchair or mobility device; therefore it is incorrect to assume that an accessible EVCS will be underutilized, because disability placard holders may have an electric vehicle or may purchase one in the near future.

For EV with the charging port at rear of the vehicle, can EV be assumed to be able to back in the parking space for easy access to the charger at the head location?

RESPONSE: This practice is not regulated by the CBC Chapter 11B accessibility provisions. DSA is not aware of any restrictions on this practice.

Are the ADA spaces ADA-only? Vans only in Van accessible spaces?

RESPONSE: Standard accessible and van accessible EVCS vehicle spaces which display the International Symbol of Accessibility (ISA), sometimes referred to as the wheelchair symbol, are generally understood to be reserved for the exclusive use of a disabled person displaying special license plates or a distinguishing placard.

Van accessible EVCS vehicle spaces which display the ISA are not reserved for vans only. They may be used by a disabled person with a standard vehicle or van displaying special license plates or a distinguishing placard.

What is best way to provide accessible curb-side EVCS (like parallel parking)?

RESPONSE: Though the building code does not regulate EVCS in the public right-of-way, accessibility is still required under the federal Americans with Disabilities Act. Since there are no explicit regulations it will be up to you to provide an accessible solution which is acceptable to the jurisdictional authorities. You may wish to refer to the new CBC Chapter 11B provisions as "guidelines" because they were crafted to address vehicle spaces that are parallel to the vehicular way as well as the more traditional pull-in space. In this case, you would apply the general requirements to curbside locations. Note that an explicit exception is provided in Section 11B-812.10.4 Exception 3.

Electric Vehicle Charging Station Sample Layouts

EV Charging Stations

Sample Layout (1 of 3)

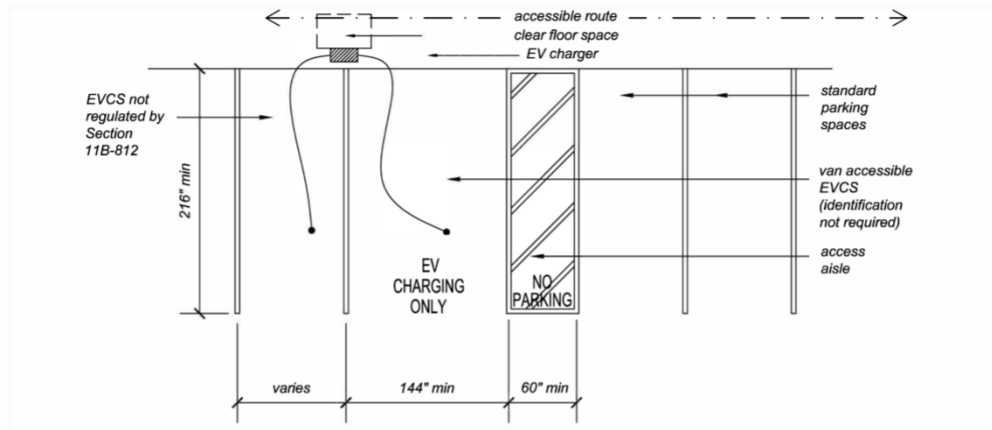

Two EVCS: one van accessible EV spaces required



EV Charging Stations

Sample Layout (2 of 3)

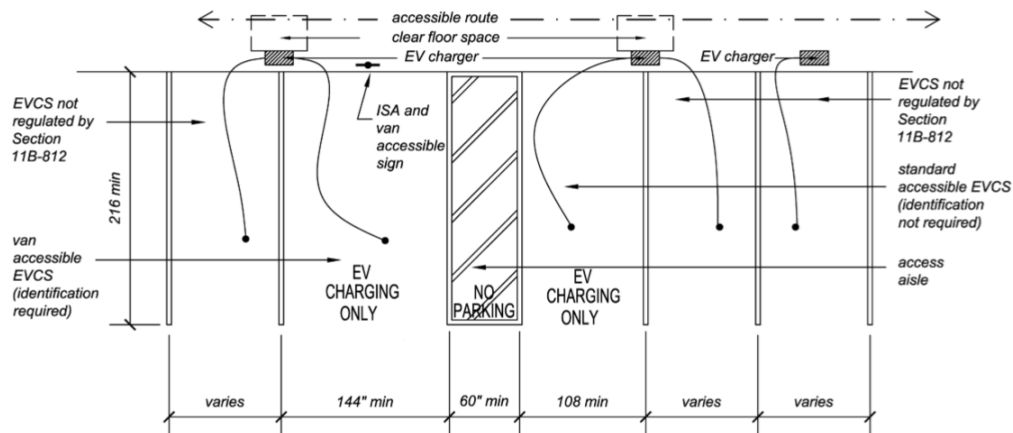

Five EVCS: two accessible EV spaces required



EV Charging Stations

Sample Layout (3 of 3)

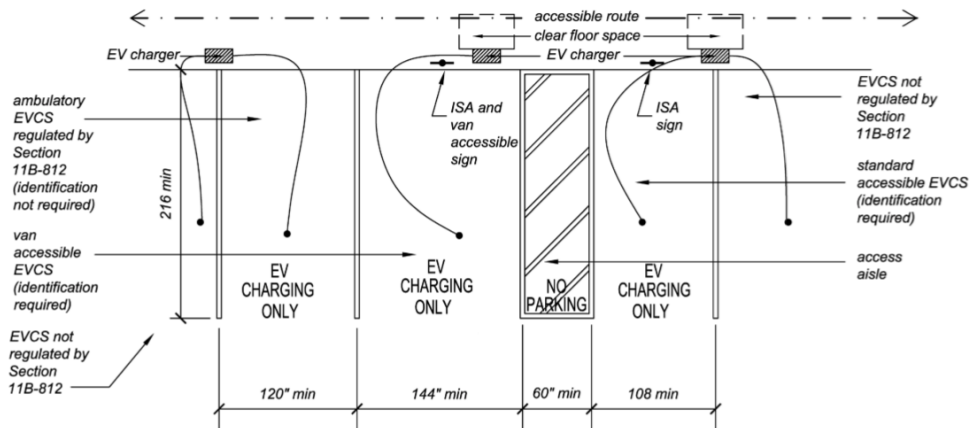

26 EVCS: three accessible EV spaces required



Source: "Access California New Accessibility Regulations for Electric Vehicle Charging Stations (EVCS)", presentation, Division of the State Architect, 2017

Appendix B

California Building Officials AB 1236 Toolkit

DRAFT



This page intentionally left blank

AB 1236 Tool Kit: Electric Vehicle Charging Stations Ordinance and Staff Report Templates – Small Jurisdictions

Resources published by the California Building Officials

As you are aware, Assembly Bill 1236 (2015) requires all local jurisdictions to adopt an ordinance with an expedited, streamlined process for permits for Electric Vehicle Charging Stations. The *effective date of the ordinance is September 30, 2017* for jurisdictions with a *resident population less than 200,000*.

- [AB 1236 Checklist Permitting Small Jurisdictions](#)
- [AB 1236 Staff Report Small Jurisdictions](#)
- [AB 1236 Model Ordinance Technical Small Jurisdictions](#)
- [AB 1236 Model Ordinance Administrative Small Jurisdictions](#)
- [AB 1236 Timeline Small Jurisdictions](#)

PLEASE NOTE: Templates are provided for your suggested use and are written for either City or County Jurisdictions. You may consider adopting an ordinance as either an Administrative Ordinance, where it would reside in your administrative chapter of your Municipal or County Code, or a Technical Ordinance, where it would be among your technical chapters. An advantage of an Administrative only Ordinance is that you will not have to create new Chapters due to legislative changes.

This Bill also requires jurisdictions to publish a Checklist that is based on the Governor's Office of Planning and Research "Plug-In Electric Vehicle Infrastructure Permitting Checklist" of the "Zero-Emission Vehicles in California: Community Readiness Guidebook".

In considering either template, please consult your City Attorney or County Council accordingly.

As always, CALBO seeks to create communication and consistency among jurisdictions. We hope that you find this AB 1236 Tool Kit useful.



(Replace with City or County logo)

CITY OR COUNTY OF _____
RESIDENTIAL AND NON-RESIDENTIAL
CHECKLIST FOR PERMITTING ELECTRIC VEHICLES
AND ELECTRIC VEHICLE SERVICE EQUIPMENT (EVSE)

Please complete the following information related to permitting and installation of Electric Vehicle Service Equipment (EVSE) as a supplement to the application for a building permit. This checklist contains the technical aspects of EVSE installations and is intended to help expedite permitting and use for electric vehicle charging.

Upon this checklist being deemed complete, a permit shall be issued to the applicant. However, if it is determined that the installation might have a specific adverse impact on public health or safety, additional verification will be required before a permit can be issued.

This checklist substantially follows the *“Plug-In Electric Vehicle Infrastructure Permitting Checklist”* contained in the *Governor’s Office of Planning and Research “Zero Emission Vehicles in California: Community Readiness Guidebook”* and is purposed to augment the guidebook’s checklist.

Job Address:	Permit No.
<input type="checkbox"/> Single-Family <input type="checkbox"/> Multi-Family (Apartment) <input type="checkbox"/> Multi-Family (Condominium)	
<input type="checkbox"/> Commercial (Single Business) <input type="checkbox"/> Commercial (Multi-Businesses)	
<input type="checkbox"/> Mixed-Use <input type="checkbox"/> Public Right-of-Way	
Location and Number of EVSE to be Installed:	
Garage _____ Parking Level(s) _____ Parking Lot _____ Street Curb _____	
Description of Work:	

Applicant Name:	
Applicant Phone & email:	
Contractor Name:	License Number & Type:
Contractor Phone & email:	
Owner Name:	
Owner Phone & email:	

EVSE Charging Level: <input type="checkbox"/> Level 1 (120V) <input type="checkbox"/> Level 2 (240V) <input type="checkbox"/> Level 3 (480V)	
Maximum Rating (Nameplate) of EV Service Equipment = _____ kW	
Voltage EVSE = _____ V	Manufacturer of EVSE: _____
Mounting of EVSE: <input type="checkbox"/> Wall Mount <input type="checkbox"/> Pole Pedestal Mount <input type="checkbox"/> Other _____	

System Voltage: <input type="checkbox"/> 120/240V, 1 ϕ , 3W <input type="checkbox"/> 120/208V, 3 ϕ , 4W <input type="checkbox"/> 120/240V, 3 ϕ , 4W <input type="checkbox"/> 277/480V, 3 ϕ , 4W <input type="checkbox"/> Other _____
Rating of Existing Main Electrical Service Equipment = _____ Amperes
Rating of Panel Supplying EVSE (if not directly from Main Service) = _____ Amps
Rating of Circuit for EVSE: _____ Amps / _____ Poles
AIC Rating of EVSE Circuit Breaker (if not Single Family, 400A) = _____ A.I.C. <i>(or verify with Inspector in field)</i>

Specify Either Connected, Calculated or Documented Demand Load of Existing Panel:
<ul style="list-style-type: none"> • Connected Load of Existing Panel Supplying EVSE = _____ Amps
<ul style="list-style-type: none"> • Calculated Load of Existing Panel Supplying EVSE = _____ Amps
<ul style="list-style-type: none"> • Demand Load of Existing Panel or Service Supplying EVSE = _____ Amps (Provide Demand Load Reading from Electric Utility)
Total Load (Existing plus EVSE Load) = _____ Amps
<p><i>For Single Family Dwellings, if Existing Load is not known by any of the above methods, then the Calculated Load may be estimated using the "Single-Family Residential Permitting Application Example" in the Governor's Office of Planning and Research "Zero Emission Vehicles in California: Community Readiness Guidebook" https://www.opr.ca.gov</i></p>

EVSE Rating _____ Amps x 1.25 = _____ Amps = Minimum Ampacity of EVSE Conductor = # _____ AWG
For Single-Family: Size of Existing Service Conductors = # _____ AWG or kcmil - or - : Size of Existing Feeder Conductor Supplying EVSE Panel = # _____ AWG or kcmil <i>(or Verify with Inspector in field)</i>

I hereby acknowledge that the information presented is a true and correct representation of existing conditions at the job site and that any causes for concern as to life-safety verifications may require further substantiation of information.

Signature of Permit Applicant: _____ Date: _____



AB 1236 Staff Report Template for Small Jurisdictions

To: Honorable Mayor and City Council / Honorable Board of Supervisors

From: Name, Community Development Director or Building Official

Subject: Adopt an Ordinance amending Chapter _____ of the City of _____ Municipal Code / County of _____ County Code by setting forth an expedited, streamlined permitting process for electric vehicle charging stations as required by Government Code Section 65850.7.

Recommended Action

Staff recommends that the City Council:

Introduce for first reading the attached ordinance which sets forth an expedited, streamlined permitting process for electric vehicle charging stations.

Executive Summary

In 2015, the State of California adopted Assembly Bill 1236 (2015, Chiu, Codified as Government Code Section 65850.7), which requires local jurisdictions with a population less than 200,000 residents to adopt an ordinance to create an expedited, streamlined permitting process for electric vehicle charging stations on or before September 30, 2017.

An electric vehicle charging station is any level of electric vehicle supply equipment station which deliver electricity from a source outside an electric vehicle into a plug-in electric vehicle. AB 1236 may refer to the recommendations in the most current version of the “Plug-In Electric Vehicle Infrastructure Permitting Checklist” of the “Zero-Emission Vehicles in California: Community Readiness Guidebook” published by the Governor’s Office of Planning and Research.

Background

Assembly Bill 1236, which amended Government Code Section 65850.7 to require jurisdictions with a population less than 200,000 residents to establish procedures for expedited, streamlined processes for permitting of electric vehicle charging stations. The amendments to Section 65850.7 include the requirement for a jurisdiction to adopt an ordinance for the expedited, streamlined process on or before September 30, 2017. The ordinance shall include the requirement that a jurisdiction adopt a checklist of requirements with which a permit application for an electric vehicle charging station will be eligible for expedited review.

This process includes the establishment of a checklist containing objective requirements for the installation of an electric vehicle charging station and a process for electronic submittal of permit applications. The content of the checklist requires the permit applicant to check the features of the existing electrical service such as rating in amperes, system voltage, connected or calculated load, spare capacity in amperes, voltage and ampere rating of the electric vehicle supply equipment, circuit rating of the electric vehicle supply equipment, location of the electric vehicle supply equipment, if ventilation is/or is not required, and clearances of the charging equipment to comply with all applicable building and fire safety laws. The checklist also assists the applicant in confirming that the location of the electric vehicle supply equipment will comply with any vehicle clearance requirements in the City’s / County’s Zoning Ordinance. Section 65850.7 requires that the City’s / County’s checklist may be based on the “Plug-In Electric Vehicle Infrastructure Permitting Checklist” of the “Zero-Emission Vehicles in California: Community Readiness Guidebook” of the Governor’s Office of Planning and Research.

Assembly Bill 1236 (2015) also clarifies that a jurisdiction shall not condition approval of a permit for an electric vehicle charging station based on the approval of an association as defined in California Civil Code, Section 4080.

Staff recommends that City Council / County Board of Supervisors introduce for First Reading the attached ordinance, given Government Code Section 65850.7's requirement that local agencies adopt such an ordinance to create an expedited, streamlined permitting process for electric vehicle charging stations on or before September 30, 2017. Most of the procedures, such as electronic submittal of plans are currently in place and comply with the requirements of the Assembly Bill and staff is assuring that successful implementation of an expedited, streamlined process will be available to permit applicants by September 30, 2017.

Building and Safety Commission Action

The Building Officer and Fire Marshal held a public meeting with the Building and Safety Commission on _____, 2017 where the Commission heard staff's proposed procedures for an expedited, streamlined process for electric vehicle charging stations. The Commission provided comments regarding balancing the requirement for expedited processing while verifying the fire, life and safety aspects of electric vehicle charging stations and maintenance of public protection. Staff intends for the application and checklist process to create a standardized system of issuing permits for compliant installations. Staff assured the Commission that all requirements of fire-life-safety will be verified during the review and inspection for the electric vehicle charging stations.

The Commission's action was a recommendation to approve the ordinance / hold the ordinance until further study.

Next Steps

Concurrent with Council's / the Board's adoption of the ordinance, staff, is taking the measures to meet all requirements of Assembly Bill 1236 (2015) by September 30, 2017. This includes finalizing the application checklist in conjunction with the "Plug-In

Electric Vehicle Infrastructure Permitting Checklist” of the “Zero-Emission Vehicles in California: Community Readiness Guidebook”, measures for electrical compliance, and standard items for fire prevention safety. Building and Fire inspection staff are also developing procedures for expedient and thorough inspection of the electric vehicle charging stations.

Financial Impacts & Budget Actions

There is no immediate financial impact or budget action necessary as a result of the recommended action.



AB 1236 Sample Ordinance Template - Technical for Small Jurisdictions

ORDINANCE NUMBER _____

AN ORDINANCE OF THE CITY COUNCIL / COUNTY BOARD OF SUPERVISORS OF
THE CITY OF _____ / COUNTY OF _____
SETTING FORTH PROCEDURES FOR EXPEDITING PERMITTING PROCESSING
FOR ELECTRIC VEHICLE CHARGING SYSTEMS

WHEREAS, the State of California and the City of _____ / County of
_____ has consistently promoted and encouraged the use of fuel-efficient electric
vehicles; and

WHEREAS, the State of California recent adopted Assembly Bill 1236, which
requires local agencies to adopt an ordinance that creates an expedited and
streamlined permitting process for electric vehicle charging systems; and

WHEREAS, creation of an expedited, streamlined permitting process for electric
vehicle charging stations would facilitate convenient charging of electric vehicles and
help reduce the City's / County's reliance on environmentally damaging fossil fuels.

NOW, THEREFORE, THE CITY COUNCIL OF THE CITY OF _____ /
COUNTY BOARD OF SUPERVISORS OF THE COUNTY OF _____ DOES
ORDAIN AS FOLLOWS:

MUNICIPAL CODE / COUNTY CODE CHAPTER _____

SECTION 1. PURPOSE

The purpose of this Chapter is to promote and encourage the use of electric vehicles by creating an expedited, streamlined permitting process for electric vehicle charging stations while promoting public health and safety and preventing specific adverse impacts in the installation and use of such charging stations. This Chapter is also purposed to comply with California Government Code Section 65850.7.

SECTION 2. DEFINITIONS

(a) “Electric vehicle charging station” or “charging station” means any level of electric vehicle supply equipment station that is designed and built in compliance with Article 625 of the California Electrical Code, as it reads on the effective date of this Chapter, and delivers electricity from a source outside an electric vehicle into a plug-in electric vehicle.

(b) “Specific, adverse impact” means a significant, quantifiable, direct, and unavoidable impact, based on objective, identified, and written public health or safety standards, policies, or conditions as they existed on the date the application was deemed complete.

(c) “Electronic submittal” means the utilization of one or more of the following:

- a. Electronic mail or email.

b. The internet.

c. Facsimile.

SECTION 3. EXPEDITED PERMITTING PROCESS

Consistent with Government Code Section 65850.7, the Building Official shall implement an expedited, streamlined permitting process for electric vehicle charging stations, and adopt a checklist of all requirements with which electric vehicle charging stations shall comply with in order to be eligible for expedited review. The expedited, streamlined permitting process and checklist may refer to the recommendations contained in the most current version of the “Plug-In Electric Vehicle Infrastructure Permitting Checklist” of the “Zero-Emission Vehicles in California: Community Readiness Guidebook” as published by the Governor’s Office of Planning and Research. The City’s / County’s adopted checklist shall be published on the City’s / County’s website.

SECTION 4. PERMIT APPLICATION PROCESSING

(a) Prior to submitting an application for processing, the applicant shall verify that the installation of an electric vehicle charging station will not have specific, adverse impact to public health and safety and building occupants. Verification by the applicant includes but is not limited to: electrical system capacity and loads; electrical system wiring, bonding and overcurrent protection; building infrastructure affected by charging station equipment and associated conduits; areas of charging station equipment and vehicle parking.

(b) A permit application that satisfies the information requirements in the City’s / County’s adopted checklist shall be deemed complete and be promptly processed. Upon confirmation by the Building Official that the permit application and supporting documents meets the requirements of the City / County adopted checklist,

and is consistent with all applicable laws and health and safety standards, the Building Official shall, consistent with Government Code Section 65850.7, approve the application and issue all necessary permits. Such approval does not authorize an applicant to energize or utilize the electric vehicle charging station until approval is granted by the City / County. If the Building Official determines that the permit application is incomplete, he or she shall issue a written correction notice to the applicant, detailing all deficiencies in the application and any additional information required to be eligible for expedited permit issuance.

(c) Consistent with Government Code Section 65850.7, the Building Official shall allow for electronic submittal of permit applications covered by this Ordinance and associated supporting documentations. In accepting such permit applications, the Building Official shall also accept electronic signatures on all forms, applications, and other documentation in lieu of a wet signature by any applicant.

SECTION 5. TECHNICAL REVIEW

(a) It is the intent of this Ordinance to encourage the installation of electric vehicle charging stations by removing obstacles to permitting for charging stations so long as the action does not supersede the Building Official's authority to address higher priority life-safety situations. If the Building Official makes a finding based on substantial evidence that the electric vehicle charging station could have a specific adverse impact upon the public health or safety, as defined in this Chapter, the City / County may require the applicant to apply for a use permit.

(b) In the technical review of a charging station, consistent with Government Code Section 65850.7, the Building Official shall not condition the approval for any

electric vehicle charging station permit on the approval of such a system by an association, as that term is defined by Civil Code Section 4080.

SECTION 6. ELECTRIC VEHICLE CHARGING STATION INSTALLATION REQUIREMENTS

(a) Electric vehicle charging station equipment shall meet the requirements of the California Electrical Code, the Society of Automotive Engineers, the National Electrical Manufacturers Association, and accredited testing laboratories such as Underwriters Laboratories, and rules of the Public Utilities Commission or a Municipal Electric Utility Company regarding safety and reliability.

(b) Installation of electric vehicle charging stations and associated wiring, bonding, disconnecting means and overcurrent protective devices shall meet the requirements of Article 625 and all applicable provisions of the California Electrical Code.

(c) Installation of electric vehicle charging stations shall be incorporated into the load calculations of all new or existing electrical services and shall meet the requirements of the California Electrical Code. Electric vehicle charging equipment shall be considered a continuous load.

(d) Anchorage of either floor-mounted or wall-mounted electric vehicle charging stations shall meet the requirements of the California Building or Residential Code as applicable per occupancy, and the provisions of the manufacturer's installation instructions. Mounting of charging stations shall not adversely affect building elements.

SECTION 7. Any provision of the City of _____ Municipal Code / County of _____ County Code or appendices thereto, inconsistent with the provisions of

this Ordinance, to the extent of such inconsistencies and no further, are hereby repealed or modified to that extent necessary to effect the provisions of this Ordinance.

SECTION 8. If any section, subsection, sentence, clause, or phrase of this Ordinance is for any reason held to be invalid or unconstitutional by a decision of any court of any competent jurisdiction, such decision shall not affect the validity of the remaining portions of this Ordinance. The City Council / County Board of Supervisors hereby declares that it would have passed this Ordinance, and each and every Section, subsection, sentence, clause, or phrase not declared invalid or unconstitutional without regard to whether any portion of the Ordinance would be subsequently declared invalid or unconstitutional.

SECTION 9. The Mayor shall sign and the City / County Clerk shall attest to the passage of this Ordinance. The City / County Clerk shall cause this Ordinance, or a summary thereof to be published once in the official newspaper within 15 days after its adoption. This Ordinance shall become effective on September 30, 2016.

APPROVED AS TO FORM:

NAME
City Attorney / County Counsel



**AB 1236 Sample Ordinance Template - Administrative
for Small Jurisdictions**

ORDINANCE NUMBER _____

AN ORDINANCE OF THE CITY COUNCIL / COUNTY BOARD OF SUPERVISORS OF
THE CITY OF _____ / COUNTY OF _____
SETTING FORTH PROCEDURES FOR EXPEDITING PERMITTING PROCESSING
FOR ELECTRIC VEHICLE CHARGING SYSTEMS

WHEREAS, the State of California and the City of _____ / County of
_____ has consistently promoted and encouraged the use of fuel-efficient electric
vehicles; and

WHEREAS, the State of California recent adopted Assembly Bill 1236, which
requires local agencies to adopt an ordinance that creates an expedited and
streamlined permitting process for electric vehicle charging systems; and

WHEREAS, creation of an expedited, streamlined permitting process for electric
vehicle charging stations would facilitate convenient charging of electric vehicles and
help reduce the City's / County's reliance on environmentally damaging fossil fuels.

NOW, THEREFORE, THE CITY COUNCIL OF THE CITY OF _____ / COUNTY BOARD OF SUPERVISORS OF THE COUNTY OF _____ DOES ORDAIN AS FOLLOWS:

SECTION 1. TITLE, WORDS AND PHRASES

This Ordinance shall be known as the City of _____ / County of _____ Electric Vehicle Charging Station Permit Expediting Ordinance. The terms, phrases, and words used in this Ordinance shall be construed in compliance with the definitions set forth by California Government Code Section 65850.7.

SECTION 2. Section _____ of the City of _____ Municipal Code / County of _____ County Code is hereby added to read as follows:

Section _____ Expedited Electric Vehicle Charging Station Permitting Electric Vehicle Charging Stations which qualify for expedited permit processing, pursuant to Government Code Section 65850.7, shall be subject to the administrative permitting procedures set forth in the City's Electric Vehicle Charging Station Permit Expediting Ordinance.

SECTION 3. EXPEDITED REVIEW PROCESS

Consistent with Government Code Section 65850.7, the Building Official shall implement an expedited administrative permit review process for electric vehicle charging stations, and adopt a checklist of all requirements with which electric vehicle charging stations shall comply with in order to be eligible for expedited review. The expedited administrative permit review process and checklist may refer to the recommendations in the checklist prescribed by the most current version of the "Plug-In Electric Vehicle Infrastructure Permitting Checklist" of the "Zero-Emission Vehicles in California: Community Readiness Guidebook" published by the Governor's Office of

Planning and Research. The City's / County's adopted checklist shall be published on the City's / County's website.

SECTION 4. ELECTRONIC SUBMITTALS

Consistent with Government Code Section 65850.7, the Building Official shall allow for electronic submittal of permit applications covered by this Ordinance and associated supporting documentations. In accepting such permit applications, the Building Official shall also accept electronic signatures on all forms, applications, and other documentation in lieu of a wet signature by any applicant.

SECTION 5. ASSOCIATION APPROVAL

Consistent with Government Code Section 65850.7, the Building Official shall not condition the approval for any electric vehicle charging station permit on the approval of such a system by an association, as that term is defined by Civil Code Section 4080.

SECTION 6. PERMIT APPLICATION PROCESSING

A permit application that satisfies the information requirements in the City's / County's adopted checklist shall be deemed complete and be promptly processed. Upon confirmation by the Building Official that the permit application and supporting documents meets the requirements of the City / County adopted checklist, and is consistent with all applicable laws, the Building Official shall, consistent with Government Code Section 65850.7, approve the application and issue all necessary permits. Such approval does not authorize an applicant to energize or utilize the electric vehicle charging station until approval is granted by the City / County. If the Building Official determines that the permit application is incomplete, he or she shall

issue a written correction notice to the applicant, detailing all deficiencies in the application and any additional information required to be eligible for expedited permit issuance.

SECTION 7. TECHNICAL REVIEW

It is the intent of this Ordinance to encourage the installation of electric vehicle charging stations by removing obstacles to permitting for charging stations so long as the action does not supersede the Building Official's authority to address higher priority life-safety situations. If the Building Official makes a finding based on substantial evidence that the electric vehicle charging station could have a specific adverse impact upon the public health or safety, as defined in Government Code 65850.7, the City / County may require the applicant to apply for a use permit.

SECTION 8. Any provision of the City of _____ Municipal Code / County of _____ County Code or appendices thereto, inconsistent with the provisions of this Ordinance, to the extent of such inconsistencies and no further, are hereby repealed or modified to that extent necessary to effect the provisions of this Ordinance.

SECTION 9. If any section, subsection, sentence, clause, or phrase of this Ordinance is for any reason held to be invalid or unconstitutional by a decision of any court of any competent jurisdiction, such decision shall not affect the validity of the remaining portions of this Ordinance. The City Council / County Board of Supervisors hereby declares that it would have passed this Ordinance, and each and every Section, subsection, sentence, clause, or phrase not declared invalid or unconstitutional without

regard to whether any portion of the Ordinance would be subsequently declared invalid or unconstitutional.

SECTION 10. The Mayor shall sign and the City / County Clerk shall attest to the passage of this Ordinance. The City / County Clerk shall cause this Ordinance, or a summary thereof to be published once in the official newspaper within 15 days after its adoption. This Ordinance shall become effective on September 30, 2016.

APPROVED AS TO FORM:

NAME

City Attorney / County Counsel



This page intentionally left blank

Appendix C

Sample Regulations to Support Electric Vehicle Infrastructure Development

DRAFT





This page intentionally left blank

Plug-In Electric Vehicle Infrastructure Permitting Checklist

Snapshot: Once a local government decides what information to require in an electric vehicle supply equipment (EVSE) permit application, it is a best practice to combine requirements and guidance into a single document that can guide plug-in electric vehicle owners through the process. This document should contain information on the conditions under which an EVSE permit is required, EVSE permit application requirements, the number and type (e.g., preinstallation, postinstallation) of inspections required and applicable codes and guidance regarding EVSE installation. The [California Plug-In Electric Vehicle Collaborative](#) created the following checklist.

Permitting Checklist		
	Residential	Non-Residential
Phase 1 Pre-Work Contractor	<ul style="list-style-type: none"> ✓ Understands intended use of the EVSE (i.e. personal) 	<ul style="list-style-type: none"> ✓ Obtain an address for the location ✓ Determine the ownership of the site and/or authorization to install equipment at site ✓ Understands intended use of the EVSE (i.e., fleet, employee, customer, visitor, etc.) ✓ Determine number of vehicles charging and connectors per charging station ✓ Determine source of power and authorization to use source
	<ul style="list-style-type: none"> ✓ Determine type of vehicle(s) to be charged at EVSE ✓ Evaluate mounting type options (i.e., bollard, pole-mount, wall-mount, ceiling-mount) ✓ Clarify communication requirements (i.e., Ethernet, cellular, Wi-Fi, none or other) ✓ Determine the NEMA Enclosure type ✓ Determine the physical dimensions of the space(s) ✓ Inspect the type of circuit breaker panel board intended for the installation 	
Phase 2 Pre-Work Customer	<ul style="list-style-type: none"> ✓ Identify incentives or rate structures through the utility ✓ Determine size of electrical service at the site ✓ Identify and contact applicable local permit office(s) to identify specific requirements, including local fire, environmental, construction, building, concealment and engineering requirements ✓ Identify incentives available through local, state or federal programs ✓ Contact insurance company to acquire additional insurance or separate coverage as needed ✓ Hire the contractor and verify credentials with all subcontractors; ensure electrical contractor's license for electrical work is current 	
Phase 3 On-Site Evaluation	<ul style="list-style-type: none"> ✓ Verify EVSE meets UL requirements and is listed by UL or another nationally recognized testing laboratory ✓ Verify EVSE has an appropriate NEMA rated enclosure (NEC 110.28) based on environment and customer needs, such as weatherization or greater levels of resistance to water and corrosive agents ✓ Determine the level or charger meets customer's PEV requirements (most vehicles require the maximum of a 240V/32A (40A breaker) ✓ Based on proposed EVSE location, determine if cord length will reach a vehicle's charging inlet without excessive slack and does not need to be more than 25' in length (NEC 625.17) ✓ Cord management methodologies have been considered to reduce the risk of tripping hazards and accidental damage to the connector ✓ Mounting type selection based on requirements to meet site guidelines ✓ Determine whether EVSE communication options are beneficial to customer and/or local utility 	
Phase 4 On-Site Survey	<ul style="list-style-type: none"> ✓ Ensure overhead doors and vehicle parking spot do not conflict with EVSE location ✓ Place EVSE in a location convenient to charging port on vehicle and 	<ul style="list-style-type: none"> ✓ Space(s) should be visible to drivers and pedestrians ✓ Determine proximity to building entrance (could be considered an incentive for PEV use)

	<p>typical orientation of the vehicle in garage (i.e., backed in or head-first)</p> <ul style="list-style-type: none"> ✓ Ensure functionality of lighting in the garage to meet NEC code 210-70 	<ul style="list-style-type: none"> ✓ Select spaces proximate to existing transformer or panel with sufficient electrical capacity ✓ EVSE installation should maintain a minimum parking space length to comply with local zoning requirements ✓ If available, use wider spaces to reduce the risk of cord damage and minimize the intersection of cords with walking paths ✓ Ensure sufficient lighting at proposed space(s) to reduce the risk of tripping and damage to charging station from vehicle impact or vandalism; light levels above two foot candles are recommended ✓ Address accessibility requirements (refer to the Plug-In Electric Vehicle Infrastructure and Equipment Accessibility section of the Guidebook for more information) ✓ Determine availability of space for informative signing ✓ EVSE with multiple cords should be placed to avoid crossing other parking spaces ✓ All available charging station mounting options should be considered and optimized for the space ✓ Determine if hazardous materials were located at the site <p>PARKING DECKS</p> <ul style="list-style-type: none"> ✓ Place EVSE towards the interior of a parking deck to avoid weather-related impacts on equipment <p>PARKING LOTS</p> <ul style="list-style-type: none"> ✓ Avoid existing infrastructure and landscaping to mitigate costs, potential hazards and other negative impacts <p>ON-STREET</p> <ul style="list-style-type: none"> ✓ Install on streets with high foot and vehicle traffic to mitigate vandalism ✓ Avoid existing infrastructure to mitigate costs, potential hazards and other negative impacts ✓ Address accessibility requirements (refer to the Plug-In Electric Vehicle Infrastructure and Equipment Accessibility section of the Guidebook for more information) ✓ For pull-in spaces, EVSE should be placed in front of the space and either centered on the space if placed between two spaces (if
--	--	---

		<p>two connectors are available); EVSE with more than two connectors should not be used in on-street applications</p> <ul style="list-style-type: none"> ✓ For parallel parking locations, the charging station should be installed at the front third of the parked vehicle and based on the direction of traffic flow; EVSE with a single connector is recommended to reduce potential trip hazards
	<ul style="list-style-type: none"> ✓ Mount the connector at a height between 36" and 48" from the ground (NEC 625.29) unless otherwise indicated by the manufacturer ✓ Install wall or pole-mount stations and enclosures at a height between 36" and 48" ✓ Ensure sufficient space exists around electrical equipment for safe operation and maintenance (NEC 110.26); recommended space is 30" wide, 3' deep and 6'6" high ✓ Minimize tripping hazards and utilize cord management technologies when possible ✓ Equipment operating above 50 volts must be protected against physical damage (NEC 110.27); ensure the vehicle is out of the line of vehicle travel and use wheel stops or other protective measures ✓ EVSE must be located such that ADA routes maintain a pathway of 36" at all times 	
<p>Phase 4 Contractor Installation Preparation</p>	<ul style="list-style-type: none"> ✓ Price quote submitted to customer and approved including utility upgrades ✓ Order equipment ✓ Provide stamped engineering calculations as needed ✓ Provide site plan modification with diagrams as necessary ✓ Complete all necessary service upgrades and/or new service assessments ✓ Complete permit applications as required by local permitting department ✓ Ensure permit is approved and collected ✓ Schedule all necessary contract work (i.e., boring, concrete and/or paving restoration) and utility work (i.e., utility marking, service upgrade, new service and/or meter pull) ✓ Ensure utility marking of existing power lines, gas lines or other infrastructure is completed and utilize "call before you dig" services 	
<p>Phase 5 Installation</p>	<ul style="list-style-type: none"> ✓ Residential garages may permit the use of nonmetallic-sheathed cable in lieu of conduit 	<ul style="list-style-type: none"> ✓ Run conduit from power source to station location ✓ For EVSE greater than 60 amperes, a separate disconnect is required (NEC 625.23) and should be installed concurrently with conduit and visible from the EVSE <ul style="list-style-type: none"> ✓ Post permit at site in visible location ✓ Remove material to run conduit and/or wiring (i.e., drywall, insulation, pavers, concrete, pavement, earth, etc. ✓ Contractors are encouraged to examine requirement for installation sites and types of wiring in Chapter 3 of the NEC ✓ Pull wiring; charging stations require a neutral line and a ground line and equipment is considered to be a continuous load ✓ Conductors should be sized to support 125% of the rated equipment load (NEC 625.21) ✓ Preparing mounting surface and install per equipment manufacturer instructions ✓ Floor-mount: typically requires a concrete foundation with J-bolts on station base; place with space to allow conductors to enter through the base ✓ Wall/pole/ceiling-mount: install brackets for mounting of the equipment

	<ul style="list-style-type: none"> ✓ Install bollard(s) and/or wheel stop(s) as needed ✓ Install informative signage to identify the EVSE and potential trip hazards ✓ Install additional electrical panels or subpanels as needed ✓ Install service upgrades, new service and/or new meter as needed; utility may also pull a meter to allow for charging station wires to be connected to a panel ✓ Make electrical connection ✓ Perform finish work to repair existing infrastructure, surfaces and landscaping
Phase 6 Inspection	<ul style="list-style-type: none"> ✓ An initial electrical inspection by applicable building, fire, environmental and electrical authorities should occur after conduit has been run and prior to connecting equipment and running wires; if necessary, contractor should correct any issues and schedule a second rough inspection ✓ If required, the inspector will perform a final inspection to ensure compliance with NEC and other codes adopted within the jurisdiction by inspecting wiring, connections, mounting and finish work ✓ Contractor should verify EVSE functionality
Additional Resources	<ul style="list-style-type: none"> ✓ National Codes and Standards ✓ American National Standards Institute (ANSI) ✓ National Fire Protection Association (NFPA) ✓ Underwriters Laboratories, Inc. (UL) ✓ International Association of Electrical Inspectors (IAEI) ✓ International Code Council (ICC) ✓ NECA-NEIS Standards ✓ NECA and NFPA Webinars ✓ Electrical Vehicle Infrastructure Training Program (EVITP) Installer Training Course/Certification

Zoning Example for Installation of Plug-In Electric Vehicle Charging Stations

Snapshot: The goal of zoning for plug-in electric vehicles charging stations should be to ensure that charging is an allowed land use in as many types of zoning districts as possible, as either an accessory or a principal use. A template for zoning electric vehicle charging stations is provided. This template is adopted from City of Lancaster's Municipal Code.

Zoning Template

- (A) An electric vehicle charging station (EVCS) shall be allowed within any legal single-family or multiple-family residential garage or carport subject to all applicable city code requirements in addition to the following.
- (1) The EVCS shall be protected as necessary to prevent damage by automobiles
 - (2) The EVCS shall be designed to:
 - (a) Be safe for use during inclement weather
 - (b) Be tamper-resistant to prevent injury particularly to children
 - (c) Be resistant to potential damage by vandalism
 - (d) Be equipped with a mechanism to prevent the theft of electricity by an unauthorized user
 - (3) The EVCS shall have complete instructions and appropriate warnings posted in an unobstructed location next to each EVCS
- (B) An EVCS shall be permitted as an accessory use within any existing legal single-family or multiple-family residential garage or carport, or within any existing legal commercial parking space in a parking lot or in a parking garage, subject to all applicable city code requirements and the following.
- (1) EVCS for public use shall be subject to the following requirements:
 - (a) The EVCSs shall be located in a manner that will be easily seen by the public for informational and security purposes and shall be illuminated during evening business hours
 - (b) Be located in desirable and convenient parking locations that will serve as an incentive for the use of electric vehicles
 - (c) The EVCS pedestals shall be protected as necessary to prevent damage by automobiles
 - (d) The EVCS pedestals shall be designed to minimize potential damage by vandalism and to be safe for use in inclement weather
 - (e) Complete instructions and appropriate warnings concerning the use of the EVCS shall be posted on a sign in a prominent location on each station for use by the operator
 - (f) One standard nonilluminated sign, not to exceed 4 square feet in area and 10 feet in height, may be posted for the purpose of identifying the location of each cluster of EVCSs
 - (g) The EVCS may be on a timer that limits the use of the station to the normal business hours of the use(s) that it serves to preclude unauthorized use after business hours
 - (2) Electric vehicle charging stations for private use shall:

- (a) Be located in a manner that will not allow public access to the charging station
- (b) Comply with subsections (B)(1)(c) and (B)(1)(d) of this section
- (c) Electric vehicle charging stations for private use not located in a single-family residential garage or carport must also comply with subsection (B)(1)(e) of this section.

Source: www.opr.ca.gov/docs/Zoning_Example_for_PEV_charging.docx

Example Building Codes for Plug-In Electric Vehicle Charging

Snapshot: Local governments can use building codes to advance plug-in electric vehicle adoption in a way that ensures safe, cost-effective installation of charging equipment. For example, by adopting more stringent building codes that require PEVready wiring in new construction, local governments can help meet future demand for charging and reduce or eliminate the costs associated with future retrofitting. Building code template language, excerpts from CALGreen and local government examples are provided. The model building code is adapted from City of Lancaster's Municipal Code.

Model Building Code for Plug-In Electric Vehicle Charging:

New residential development shall provide for electric vehicle charging stations (EVCSs) in the following prescribed manner.

1. Garages serving each new single-family residence and each unit of a duplex shall be constructed with a listed cabinet, box or enclosure connected to a raceway linking the garage to the electrical service, in a manner approved by the building and safety official, to allow for the future installation of electric vehicle supply equipment to provide an EVCS for use by the resident.
2. In new multiple-family projects of 10 dwelling units or less, 20% of the total parking spaces required (all of the 20% shall be located within the required covered parking) shall be provided with a listed cabinet, box or enclosure connected to a conduit linking the covered parking spaces or garages with the electrical service, in a manner approved by the building and safety official, to allow for the future installation of electric vehicle supply equipment to provide EVCSs at such time as it is needed for use by residents. EVCSs shall be provided in disabled parking spaces in accordance with state and federal requirements.
3. In new multiple-family projects of more than 10 dwelling units, 10% of the total parking spaces required (all of the 10% shall be located within the required covered parking) shall be provided with a listed cabinet, box or enclosure connected to a conduit linking the covered parking spaces or garages with the electrical service, in a manner approved by the building and safety official. Of the total listed cabinets, boxes or enclosures provided, 50% shall have the necessary electric vehicle supply equipment installed to provide active EVCSs ready for use by residents. The remainder shall be installed at such time as they are needed for use by residents. EVCSs shall be provided in disabled parking spaces in accordance with state requirements.

New commercial development shall provide for electric vehicle charging stations in the following prescribed manner.

1. New residential uses shall provide EVCSs in accordance with the New Residential Development section.

2. New commercial, industrial and other uses with the building or land area, capacity or numbers of employees listed herein shall provide the electrical service capacity necessary and all conduits and related equipment necessary to ultimately serve 2% of the total parking spaces with EVCSs in a manner approved by the building and safety official. Of these parking spaces, 1/2 shall initially be provided with the equipment necessary to function as online EVCSs upon completion of the project. The remainder shall be installed at such time as they are needed for use by customers, employees or other users. EVCSs shall be provided in disabled person parking spaces in accordance with state and federal requirements.

a. Construction of a hospital of 500 or more beds, or expansion of a hospital of that size by 20% or more.

b. Construction of a postsecondary school (college), public or private, for 3,000 or more students, or expansion of an existing facility having a capacity of 3,000 or more students by an addition of at least 20%.

c. Hotels or motels with 500 or more rooms.

d. Industrial, manufacturing or processing plants or industrial parks that employ more than 1,000 persons, occupy more than 40 acres of land or contain more than 650,000 square feet of gross floor area.

e. Office buildings or office parks that employ more than 1,000 persons or contain more than 250,000 square feet of gross floor area.

f. Shopping centers or trade centers that employ 1,000 or more persons or contain 500,000 square feet of gross floor area.

g. Sports, entertainment or recreation facilities that accommodate at least 4,000 persons per performance or that contain 1,500 or more fixed seats.

h. Transit projects (including but not limited to transit stations and park and ride lots).

CALGreen

For one- and two-family dwellings, the CALGreen code offers a voluntary standard that, if adopted, calls for installation of a raceway to accommodate a dedicated branch circuit. For multifamily residential dwellings of three stories or less, CALGreen also provides an option to establish a minimum number of parking spaces to be capable of supporting PEV charging. The CALGreen code language is excerpted (California Building Standards Commission July 1, 2012 Supplement):

A4.106.6.1 One- and two-family dwellings. Install a listed raceway to accommodate a dedicated branch circuit. The raceway shall not be less than trade size 1. The raceway shall be securely fastened at the

main service or subpanel and shall terminate in close proximity to the proposed location of the charging system into a listed cabinet, box or enclosure. Raceways are required to be continuous at enclosed or concealed areas and spaces. A raceway may terminate in an attic or other approved location when it can be demonstrated that the area is accessible and no removal of materials is necessary to complete the final installation.

A4.106.6.2 Multifamily dwellings. At least 3 percent of the total parking spaces, but not less than one, shall be capable of supporting future EVSE.

A4.106.6.2.1 Single charging space required. When only a single charging space is required, install a listed raceway capable of accommodating a dedicated branch circuit. The raceway shall not be less than trade size 1. The raceway shall be securely fastened at the main service or subpanel and shall terminate in close proximity to the proposed location of the charging system into a listed cabinet, box or enclosure.

A4.106.6.2.2 Multiple charging spaces required. When multiple charging spaces are required, plans shall include the location(s) and type of the EVSE, raceway method(s), wiring schematics and electrical calculations to verify that the electrical system has sufficient capacity to charge simultaneously all the electrical vehicles at all designated EV charging spaces at their full rated amperage. Plan design shall be based upon Level 2 EVSE at its maximum operating ampacity. Only underground raceways and related underground equipment are required to be installed at the time of construction.

CALGreen also offers municipalities a voluntary standard for PEV charging at commercial, retail and other nonresidential locations, as excerpted (California Building Standards Commission 2012 Supplement):

A5.106.5.3 Electric vehicle charging. Provide facilities meeting Section 406.7 (Electric Vehicle) of the California Building Code and as follows:

A5.106.5.3.1 Electric vehicle supply wiring. For each space required by Table A5.106.5.3, provide panel capacity and dedicated conduit for one 208/240V 40-amp circuit terminating within 5 feet of the midline of each parking space.

Table A5.106.5.3.1:

TOTAL NUMBER OF PARKING SPACES*	NUMBER OF REQUIRED SPACES
1–50	1
51–200	2
201 and over	4

Local Government Examples

Beverly Hills

Provide facilities meeting section 406.7 (Electric Vehicle) of the California building code and as follows: One 120 VAC 20 amp and one 208/240V 40 amp, grounded AC outlets or panel capacity for one 120 VAC 20 amp and one 208/240V 40 amp, grounded AC outlet and conduit installed for future outlets for each dwelling unit. Electric vehicle supply equipment shall be provided and may be installed in a stall provided to comply with the code minimum parking requirements. Dwelling unit shall be defined by the California building code. Exception: Apartment buildings and apartment units (Beverly Hills Municipal Code 2011).

City of Los Angeles

1. For one- or two-family dwellings and townhouses, provide a minimum of:
 - a. One 208/240 V 40-amp, grounded AC outlet, for each dwelling unit; or
 - b. Panel capacity and conduit for the future installation of a 208/240 V 40-amp, grounded AC outlet, for each dwelling unit. The electrical outlet or conduit termination shall be located adjacent to the parking area.
2. For other residential occupancies where there is a common parking area, provide one of the following:
 - a. A minimum number of 208/240 V 40-amp, grounded AC outlets equal to 5 percent of the total number of parking spaces. The outlets shall be located within the parking area; or
 - b. Panel capacity and conduit for future installation of electrical outlets. The panel capacity and conduit size shall be designed to accommodate the future installation, and allow the simultaneous charging, of a minimum number of 208/240 V 40-amp, grounded AC outlets, that is equal to 5 percent of the total number of parking spaces. The conduit shall terminate within the parking area; or
 - c. Additional service capacity, space for future meters, and conduit for future installation of electrical outlets. The service capacity and conduit size shall be designed to accommodate the future installation, and allow the simultaneous charging, of a minimum number of 208/240 V 40-amp, grounded AC outlets, that is equal to 5 percent of the total number of parking spaces.

The conduit shall terminate within the parking area. When the application of the 5 percent results in a fractional space, round up to the next whole number. (Los Angeles Municipal Code 2010)

Rolling Hills Estates

Any new residential construction, including an addition to a residential structure of greater than 50 percent of the existing floor area, including the primary garage, and/or any demolition of greater than 50 percent of the lineal walls of a residential structure within a twelve-month period, shall require the installation of a 220-volt dedicated electrical outlet in the garage for the purposes of charging an electric vehicle. (Rolling Hills Estates Municipal Code)

Temecula

Circuits for electric vehicle charging stations shall meet all the requirements of California Electrical Code Article 62540. Residential garages shall have a minimum three-quarter (3/4) inch metal flex conduit ran from meter box to the garage firewall and terminated in a metal box at forty-two (42) inches above finished floor for future electric vehicle charging station. (Temecula Municipal Code)